

FUMIRA

Leading Innovation of Galvanized Steel



OVERVIEW

FUMIRAGRIP®

- Continuous Galvanizing Line
- Raw Material, Facilities, Processes and Products
- FUMIRAGRIP Advantages
- Skin Pass Process Advantages
- Usage
- Pot and Coating Layer
- Product Specification
- Available Dimensions

COLORPRODUCTS

- Continuous Color Line
- Color Standards

COMPODECK®

- COMPODECK Advantages
- Base Material
- Installation
- Concreting
- Effective Span

ROOF & SIDING

- FUMIRA Projects
- Long span roof
- Middle span roof
- Conventional Wall and Fascia
- Installation
- Flashing Standard
- Storage

QUALITY STANDARD

- Quality Standards

WAVE PROFILE



Overview

Fumira is one of the largest galvanized steel sheet producer in Indonesia. Fumira was established in 1970 and the name of Fumira was came from the two first letter of the three share holders, i.e. Fuji Steel (later , **Fuji Steel** merged with Yawata Steel to become Nippon Steel Corp.), **Mitsui Co. Ltd.** and **Ragam Logam** (a subsidiary of Argo Manunggal Group). Eventhough current Fumira's share holders has changed, our missison to provide high quality products and services are maintaned.

The first Fumira's factory was built in 1970 in Semarang, Central Java, producing famous high quality product of corrugated galvanized steel sheet (GI) branded Moon Elephant. The second factory was built in 1997 in Bekasi, West Java. It was the first factory in indonesia which is using Continuous Galvanizing Line (CGL) with Non-Oxidizing Furnace (NOF) system, technology of Nippon Steel Corp., Japan. This system produce an excelent zinc coating quality (lock forming quality) product, called FUMIRAGRIP, which has bendabilty to zero gap thickness without crack nor peeled off. This coating quality is ideal for industrial use, particulary in automotive and construction such as oil and air filters, car bodies, steel frames, partition, roof, siding and deck.

Fumira is an innovative company, where in 1979, Fumira has succeeded in developing color coated galvanized steel sheet in Fumira originally designed Color Coating Line in 1979. Based on experience in operating color line, Fumira installed a modern Continuous Color Line in 2014 to increase the production capacity as well as to expand product types and quality.

All year long of Fumira's operation, there are facilities have been acquired to provide the best products and services to the customers such as, Shearing Lines , Corrugating machine, and Roll Forming machine in many types of product wave profile. Now, Fumira have become stronger and always innovating to deal with transformation to meet customer need and committed to work closely with them as well as with disributors and suppliers.

Selayang pandang

Fumira adalah salah satu produsen terbesar baja lembaran galvanis di Indonesia. Fumira didirikan pada tahun 1970 dan nama Fumira itu berasal dari dua huruf pertama dari tiga pemegang saham , yaitu **Fuji Steel** (kemudian, Fuji Steel bergabung dengan Yawata Steel untuk menjadi Nippon Steel Corp.), **Mitsui Co Ltd** dan **Ragam Logam** (anak perusahaan dari Argo Manunggal Group). Walaupun pemegang saham Fumira saat ini telah berubah, misi kami untuk menyediakan produk berkualitas dan layanan yang tinggi tetap terpelihara.

Pabrik FUMIRA yang pertama dibangun pada tahun 1970 di Semarang, Jawa Tengah, memproduksi produk berkualitas tinggi terkenal lembaran baja galvanis (GI) gelombang bermerek Moon Elephant. Pabrik yang kedua dibangun pada tahun 1997 di Bekasi, Jawa Barat. Pabrik ini adalah pabrik pertama di Indonesia yang menggunakan *Continuous Galvanizing Line (CGL)* dengan sistem Non-Oxidation Furnace (NOF), teknologi dari Nippon Steel Corp, Jepang. Sistem ini menghasilkan produk dengan kualitas lapisan seng terbaik (kualitas *lock forming*), yang disebut FUMIRAGRIP® , yang memiliki daya tekuk dengan tanpa celah, tanpa retak atau terkelupas. Kualitas *coating*/pelapis ini sangat ideal untuk keperluan industri, khususnya dalam konstruksi dan otomotif seperti saringan oli udara, badan mobil, rangka baja, partisi, atap, dinding, dan dek.

Fumira adalah perusahaan yang inovatif, di mana Fumira telah berhasil dalam mengembangkan produk baja lembaran galvanis lapis warna yang dihasilkan *Color Coating Line* yang berasal dari rancangan Fumira pada tahun 1979. Berdasarkan pengalaman dalam operasi *Color Line*, Fumira memasang *Continuous Color Line* modern di tahun 2014 untuk meningkatkan kapasitas produksi serta untuk memperluas jenis produk dan kualitas.

Sepanjang masa operasi Fumira, banyak fasilitas telah dimiliki untuk menyediakan produk dan layanan terbaik kepada para pelanggan seperti, Shearing Lines, mesin Corrugating, dan mesin Roll Forming dalam berbagai jenis profil gelombang produk. Sekarang Fumira telah menjadi lebih kuat dan selalu berinovasi untuk menghadapi transformasi untuk memenuhi kebutuhan pelanggan dan berkomitmen untuk bekerja sama dengannya sebagaimana dengan para disributor dan pemasok.

CGL (Continuous Galvanizing Line)

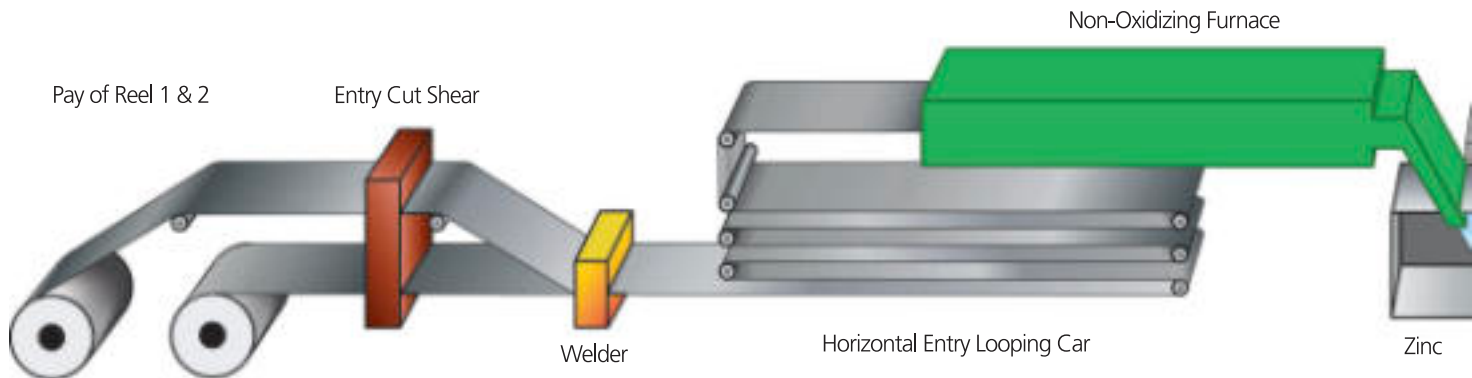

Raw material, facilities, processes and product | Bahan baku, fasilitas, proses & produk



Raw material

The raw material is full hard (unannealed) Cold Rolled Steel Sheet in Coil (CRC), as specified in JIS G3141 and SNI 07-3567 standards and they will be processed for full hard (unannealed) and soft (annealed) products, depending on the product end usage. The raw material is uncoiled in the Pay Off Reel to be processed as a long strained steel strip along the Line.

Bahan baku

Bahan baku adalah baja gulungan canai dingin *full hard* (tidak dianil) sesuai spesifikasi dalam standar JIS G3141 dan SNI 07-3567, baik untuk produk *full hard* (tidak dianil) maupun lunak (dianil), tergantung pada penggunaan akhir produk. Bahan baku ini dibuka di *Pay Off Reel* untuk diproses sebagai bentangan panjang lembaran baja panjang sepanjang *Line*.



Horizontal Entry and Delivery Looping Car

The facilities to accumulate the strain of cold rolled steel strip horizontally at the entry side and supply to the galvanizing process continuously during the welding, to join the previous to the next steel strip, and to accumulate the galvanized product strain horizontally at the exit side, during the product inspection and cutting, while galvanizing process is continuously running.

Looping Car Horizontal Entry and Exit

Fasilitas untuk menampung bentangan lembaran baja canai dingin secara horizontal pada bagian entry dan memasok proses galvanis secara berkesinambungan pada saat proses pengelasan, untuk menyambung lembaran baja sebelumnya dengan sesudahnya, dan untuk menampung bentangan produk galvanis secara horizontal pada bagian *exit*, ketika inspeksi produk dan pemotongan, sementara proses galvanis berjalan berkesinambungan.



Non-Oxidizing Furnace

The process where the raw material of cold rolled steel strip is passed through a set of furnaces to pre-heat and clean its surface from oil and dirt, and anneal in the Non-Oxidizing furnace (NOF) to get the required mechanical properties, full hard (unannealed) or soft (annealed) and to cool it down to the suitable temperature for hot dip galvanizing process.

Tungku Non-Oxidizing

Proses dimana bahan baku berupa lembaran baja canai dingin dilewatkan melalui satu set tungku untuk pemanasan awal dan pembersihan permukaannya dari minyak dan kotoran, serta penganilan dalam tungku *Non-Oxidizing* untuk mendapatkan sifat mekanik yang diperlukan, *full hard* (tidak dianil) atau lunak (dianil) dan untuk mendinginkannya ke temperatur yang sesuai untuk proses galvanisasi celup panas.

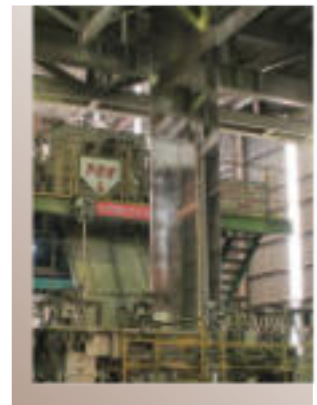

Hot dip galvanizing

The process where the cleaned and annealed cold rolled steel strip from the furnaces is then hot dipped into a temperature controlled zinc bath which is linked through a sealed snout to prevent oxidation from outside air and give a very strong zinc coating to its surface. The thickness and the uniformity of zinc coating is controlled by Air Jet Wiping (AJW) system.

Galvanisasi celup panas

Proses dimana bahan baku berupa lembaran baja canai dingin yang telah dibersihkan dan dianil dari tungku kemudian dicelupkan ke dalam cairan seng panas yang suhunya dikontrol yang terhubung melalui saluran tertutup untuk mencegah oksidasi dari udara luar dan memberikan lapisan seng yang sangat kuat ke permukaannya. Ketebalan dan keseragaman lapisan seng dikendalikan oleh sistem *Air Jet Wiping (AJW)*.

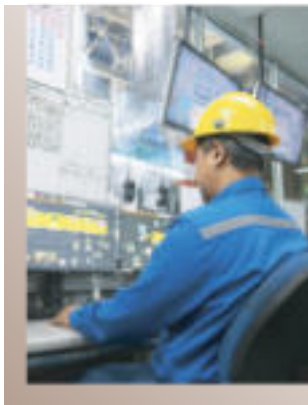
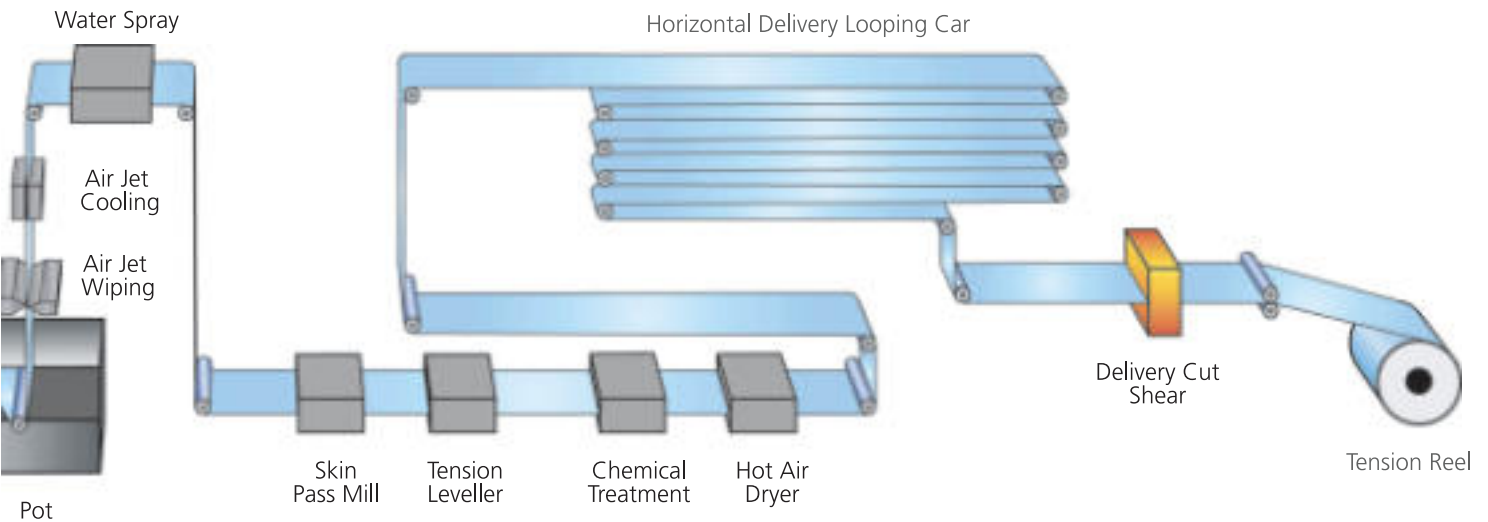

Control room

A place where the entire operation of machineries and processes are controlled and monitored. Among activities, especially, the machineries synchronization, line speed, furnaces temperature, furnace atmosphere condition and zinc bath temperature, are set by computerization system.

Ruang kendali

Sebuah tempat dimana seluruh operasi mesin dan proses dikendalikan dan dimonitor. Diantara aktivitas, khususnya, sinkronisasi mesin, kecepatan line, temperatur tungku, kondisi atmosfer tungku dan temperatur cairan seng, ditetapkan menggunakan sistem komputerisasi.

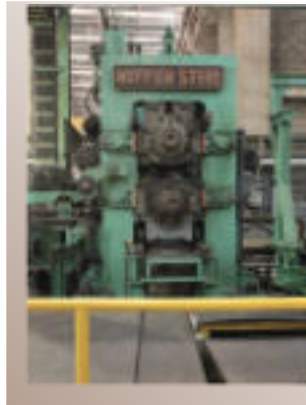

Skin pass mill

The facility which consist of a pair of rolls (2-High system) with specified roughness where galvanized steel sheet product is rolled by passing it through them, especially, to increase its surface paintability for the painting and color coating.

Skin pass mill

Fasilitas yang terdiri dari sepasang roll (sistem 2-High) dengan kekasaran tertentu di mana produk baja lembaran galvanis dicanaikan dengan melewatkan melaluinya, terutama, untuk meningkatkan mampu cat permukaannya untuk pengecatan dan pelapisan warna.



Post production treatments and inspection

There are two process of post production treatment, i.e., the processes of tension levelling by Tension Leveller to improve the mechanical properties and product shape and surface chemical treatments to prevent the product from rust during storage.

Inspections is done at the inspection table prior to the recoiling in the Tension Reel to ensure that products produced meet with the customer requirements. The whole length of product are inspected for their surface and shape quality and samples are taken to be further tested according to product quality testing procedure

Perlakuan pasca produksi dan inspeksi

Terdapat dua proses paska produksi, yaitu, proses penarikan dan perataan menggunakan *Tension Leveller* untuk memperbaiki sifat mekanik dan bentuk produk dan perlakuan kimia permukaan untuk mencegah produk dari karat selama penyimpanan. Inspeksi dilakukan pada meja inspeksi sebelum penggulungan kembali di *Tension Reel* untuk memastikan produk yang dihasilkan sesuai dengan kebutuhan pelanggan. Keseluruhan panjang produk diinspeksi kualitas permukaan dan bentuknya, contoh diambil untuk dilakukan uji lebih lanjut sesuai dengan prosedur uji kualitas produk.

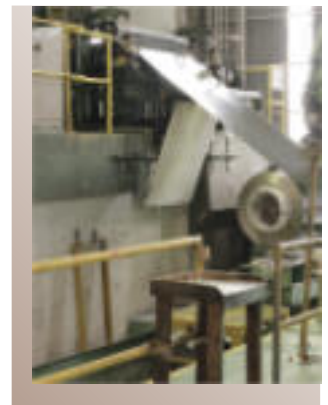

Product

The Product produced is galvanized steel strip in coil, as specified in JIS G3302 and SNI 07-2053 standards. Fumira has developed galvanized steel sheet product which fulfill the specification standards. Fumira's brand product called FUMIRAGRIP which describe the excellent zinc coating quality (lock forming quality) of bendability to zero gap thickness without peeled off. The product is recoiled in the Tension Reel to be a coil forms and cut according to customer's weight requirement.

Produk

Produk yang dihasilkan adalah gulungan lembaran baja galvanis, sebagaimana ditentukan dalam standar JIS G3302 dan SNI 07-2053. Fumira telah mengembangkan produk lembaran baja galvanis yang memenuhi standar spesifikasi. Merek produk Fumira disebut FUMIRAGRIP yang menggambarkan kualitas lapisan seng yang terbaik (kualitas *lock forming*) dengan mampu tekuk hingga celah nol ketebalan tanpa mengelupas. Produk digulung kembali di *Tension Reel* menjadi bentuk gulungan dan dipotong sesuai kebutuhan berat dari pelanggan.

FUMIRAGRIP Advantages | Keunggulan FUMIRAGRIP

FUMIRAGRIP®

- Produced by the latest technology of Non-Oxidizing Furnace (NOF) system.
- Lock forming quality of zinc coating with bendability to zero gap thickness without peeled off.
- Free of latent corrosion attack due to direct firing method to clean the steel surface cleaning in the Non-Oxidizing Furnace (NOF) system prior to galvanizing process.
- Metallic surface appearance.
- Minimized spangles without deep spangles border.
- Non hazardous zinc coating quality standard (less than 0,03% Pb) which is comply to the European Union of RoHS (Restriction of Hazardous Substance directive 2011/65/EU).

Other brands

- Mainly produced by the conventional galvanizing system which allow oxidation by air in the heating furnace.
- Non lock forming quality of zinc coating that peeled off when it bent to zero gap thickness.
- Latent corrosion attack due to remained hazardous chemical element at the steel surface from the chemical cleaning prior to galvanizing process.
- Dull surface appearance.
- Big spangles with deep spangles border.
- Hazardous zinc coating system due to the lead bath usage.

FUMIRAGRIP®

- Dihasilkan menggunakan teknologi terkini sistem *Non-Oxidizing Furnace (NOF)*.
- Kualitas pelapisan seng lock forming dengan mampu tekuk hingga celah nol ketebalan tanpa mengelupas.
- Bebas dari serangan karat laten karena menggunakan metode pembakaran langsung untuk membersihkan permukaan baja di dalam sistem tungku *Non-Oxidizing* sebelum proses galvanisasi.
- Penampakan permukaan yang metalik.
- Spangles yang minimum dan tanpa batas spangles yang dalam.
- Menggunakan standar kualitas bahan baku zinc tidak berbahaya (kurang dari 0,03% Pb) yang mematuhi RoHS (Pembatasan Bahan Berbahaya direktif 2011/65 /EU).

Merk lain

- Terutama diproduksi oleh sistem galvanizing konvensional yang memungkinkan oksidasi oleh udara dalam tungku pemanas.
- Kualitas pelapisan seng *non-lock forming* yang terkelupas ketika ditekuk hingga celah nol ketebalan.
- Laten korosi serangan karena sisa unsur kimia berbahaya pada permukaan baja dari pembersih kimia sebelum proses galvanizing.
- Penampilan permukaan kusam.
- Spangles besar dengan batas spangles yang dalam.
- Sistem pelapisan seng yang berbahaya karena penggunaan cairan timbal.

Skin passed and tension levelled process advantages | Keunggulan diproses Skin Pass dan Tension Leveler



Non skin passed / tidak diskinn pass



Skin passed / diskinn pass

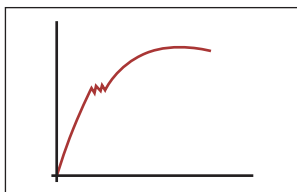

Non Tension Levelled

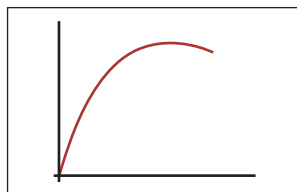

Tension Levelled

1 Surface roughness adjustment

Uniform surface appearance.
Better Paintability

Pengaturan kekasaran permukaan.

Penampilan permukaan yang merata.
Mampu cat yang lebih baik.

2 Improvement in mechanical properties

Better formability due to yield point removal

Perbaikan dalam sifat mekanik

Mampu bentuk yang lebih baik karena penghilangan titik luluh.

Al-Zn coated product | Produk lapis Al-Zn

Fumira also provides AlZn coated steel sheet. The coating layer contains approximately 55% of Aluminum, 43.5 % of Zinc and 1.5% of Silicon.

The product is produced by the similar technology of continuous hot dip coating process. The product has excellent corrosion performance and forming abilities.

Fumira provides the AlZn coated product with the optimal coating weight of 150 gr/m² (AZ-150).

Fumira juga menyediakan baja lembaran berlapis AlZn . Lapisan permukaan mengandung sekitar 55% dari Aluminium, 43,5 % Zinc dan 1,5% Silicon.

Produk ini diproduksi oleh teknologi yang serupa dengan proses pelapisan celup panas yang berkesinambungan. Produk ini memiliki daya tahan korosi dan mampu bentuk yang sangat baik.

Fumira menyediakan produk AlZn dengan berat lapisan yang optimal yaitu 150 gr/m² (AZ-150).

Usage | Pemakaian

FUMIRAGRIP® end usage is vary depend on its specification and available in coil and plate in various size and weight to fulfill customers requirement.

Some examples of the FUMIRAGRIP® end usage:

- | | |
|----------------------------|---|
| BUILDING | : Roofing
: Siding
: Ceiling
: Gutter
: Floordecking
: Partitions
: Ducting
: Fence etc. |
| ELECTRICAL & MACHINERY | : Air Conditionings
: Cooling Units
: Elevators
: Fans
: Panels
: Refrigerators & Freezer |
| MOTOR VEHICLES /AUTOMOTIVE | : Automobile Heat Shields
: Pickup Load Box
: Bus Bodies
: Air & Oil Filters |
| OFFICE & EQUIPMENT | : Filling Cabinets
: Lockers
: Show Cases
: Cable Covers |
| OTHERS | : Billboard
: Container
: Packaging
: Drainage |

Penggunaan akhir FUMIRAGRIP® bervariasi tergantung spesifikasinya dan tersedia dalam bentuk gulungan dan pelat dengan ukuran dan berat yang bervariasi untuk memenuhi kebutuhan pelanggan.

Beberapa contoh penggunaan FUMIRAGRIP® :



Pot & coating layer | Pot & pelapisan

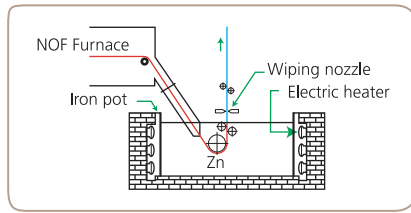

Pot of FUMIRA System (Sistem pot CGL FUMIRA)
Cold rolled steel strip is hot dipped from the NOF into zinc bath through a sealed snout.
(Lembaran baja canai dingin dicelup panas dari NOF kedalam cairan seng melalui saluran tertutup)

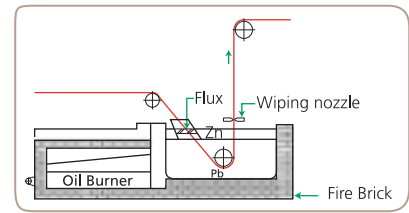

Pot of wet Flux Conventional System (Sistem pot konvensional fluks basah)
Cold rolled steel strip is hot dipped into zinc bath in open air.
(Lembaran baja canai dingin dicelup panas kedalam cairan seng didalam udara terbuka)

FUMIRAGRIP® cross section galvanize coating layer Perbandingan penampang lapisan galvanis FUMIRAGRIP®



FUMIRAGRIP® NOF system / Sistem NOF

Thin and ductile of intermetallic Fe-Zn alloy layer at the steel and zinc interface.
(Lapisan paduan intermetallic Fe-Zn yang Tipis dan ulet pada antar muka baja dan seng)

Other Brand / Merek lain

Thick and brittle of intermetallic Fe-Zn alloy layer at the steel and zinc interface.
(Lapisan paduan intermetallic Fe-Zn yang tebal dan getas pada antar muka baja dan seng)

Product specification | Spesifikasi produk

1. Product type | Jenis produk

ASTM

Old symbol	Current Symbol	Quality
A 526	A 653 Commercial Steel (CS) Type A and B	Commercial, Lock Forming / Komersial Lock Forming
A 527	A 653 Forming Steel (FS) Type A and B	Lock Forming / Lock Forming
A 642 *)	A 653 Deep Drawing Quality (DDS) Type B	Deep Drawing / Pembentukan dalam
A 446	A 653 Structural Steel (SS) Grade 550	Structural/ Struktur

JIS 3302

Symbol	Quality
SGCC	Commercial Soft/ Komersial Lunak
SGCH	Commercial Hard/ Komersial Keras
SGCD 1, 2, 3*)	Drawing/ Pembentukan dalam 1, 2, 3*)
SGC 340	Structurural/ Struktur
SGC 400	Structurural/ Struktur
SGC 550	Structurural/ Struktur

*) Should be discussed during the product purchasing
Harus didiskusikan pada saat pembelian produk

2. Coating weight | Berat lapisan

SPECIFICATION			Average Coating Mass
ASTM 653M (Metric)	JIS G3302	SNI 2053	Triple spot test on both surfaces
Z 275	Z 27	Z 27	275
-	Z 25	Z 25	250
-	Z 22	Z 22	220
-	Z 20	Z 20	200
Z 180	Z 18	Z 18	180
Z 120	Z 12	Z 12	120
-	Z 10	Z 10	100
-	Z 08	Z 08	80

3. Post Treatment | Perlakuan pasca

Treatment	Application
Unchromated and Dry Chromated and Dry	Phosphating and Painting General purpose

4. Finished surface coating properties | Sifat akhir lapisan permukaan

Spangle	Surface finished
Minimized Minimized	Not Skinpassed Skinpassed

5. Available Sizes | Ukuran yang tersedia

- | | | | |
|---------------------------------|--|---------------------------------|--|
| • Thickness | : 0.20 mm up to 1.20 mm
(Based Metal Thickness) | • Tebal | : 0.20 mm sampai dengan 1.20 mm
(Tebal Logam Dasar) |
| • Width | : 650 mm up to 1219 mm | • Lebar | : 650 mm sampai dengan 1250 mm |
| • Length | : Sheet = Meter length/pieces
: Roll = Meter length (max. 50 m) / Roll
: Coil = Ton/Coil | • Panjang | : Sheet = Panjang meter/lembar
: Roll = Meter panjang (max. 50 m)/Roll
: Coil = Ton/Coil |
| • Coil Inside Diameter | : 508 mm and 610 mm | • Diameter Dalam Coil | : 508 mm dan 610 mm |
| • Coil Weight | : Min. 2,0 MT, max. 8,0 MT | • Beraty Coil | : Min. 2,0 MT, maks. 15 MT |
| • Thickness and Width Tolerance | : According to SNI 07-2053
JIS 3302 and ASTM 653 M | • Toleransi Tebal dan Lebar | : Menurut SNI 07-2053
JIS 3302 dan ASTM 653 M |
| • Flatness and Shape Tolerance | : According to SNI 07-2053
JIS 3302 and ASTM 653 M | • Toleransi kerataan dan bentuk | : Menurut SNI 07-2053
JIS 3302 dan ASTM 653 M |

6. Mechanical properties | Sifat mekanik

PRODUCT	Thickness (mm)	Hardness (HR30T)	Yield Strength (Mpa)	Tensile Strength (Mps)	Elongation (%)
Unannealed	0.20 - 1.20	76 - 80	550 - 700	570 - 720	2 - 5
Annealed	0.20 - 1.20	50 - 60	245 - 295	340 - 400	28 - 38

CCL (Continuous Color Line)

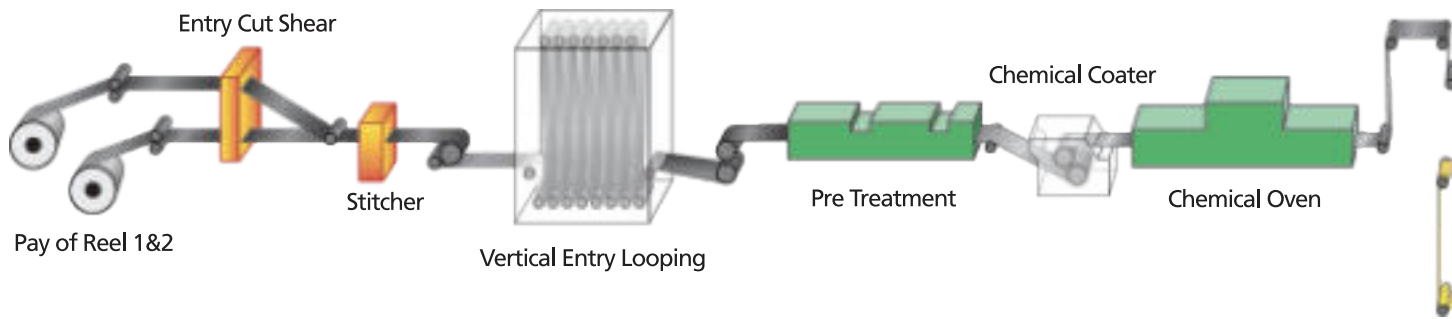

Color Standard | Standar warna

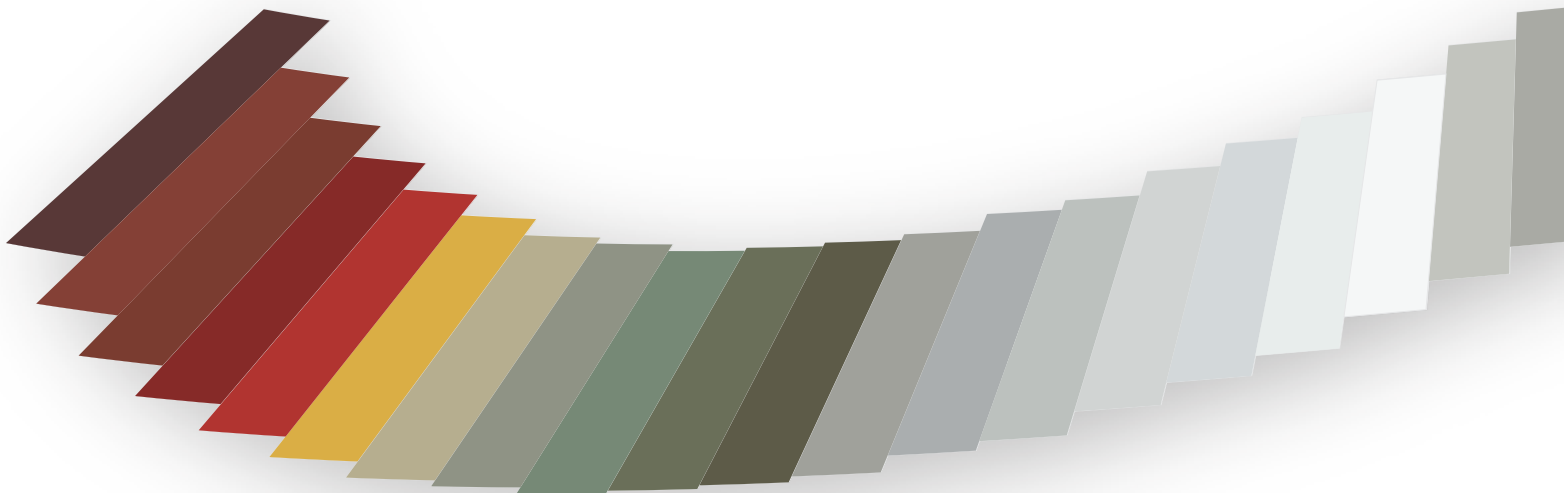

FUMIRA Color coating detail section | Bagian detail lapisan color coating FUMIRA

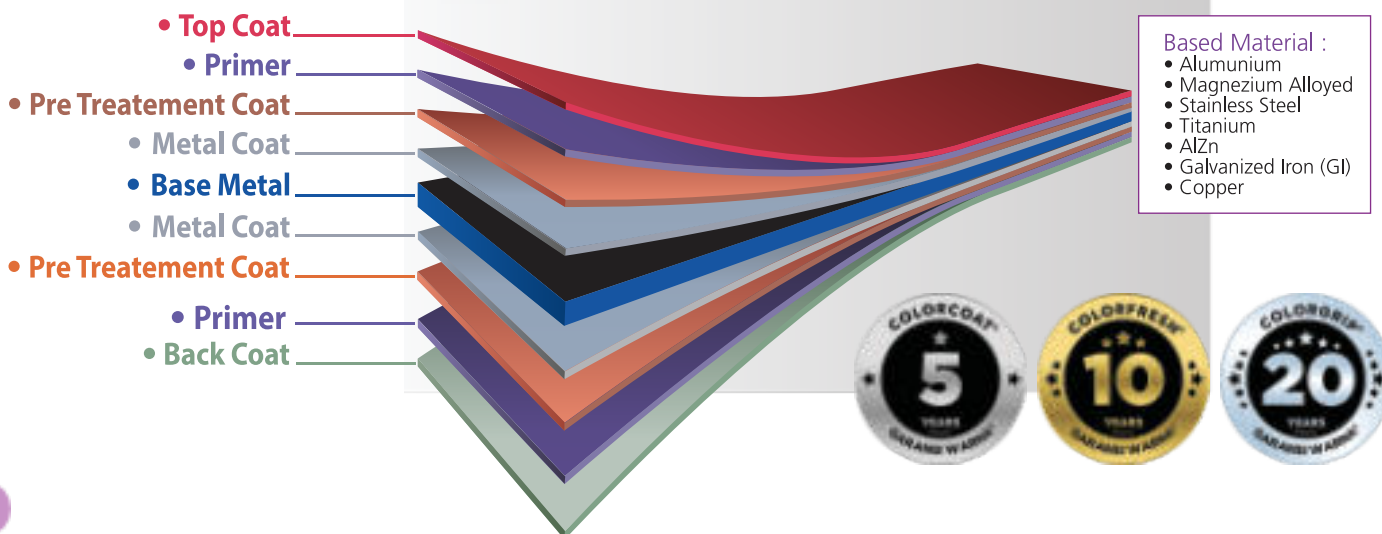

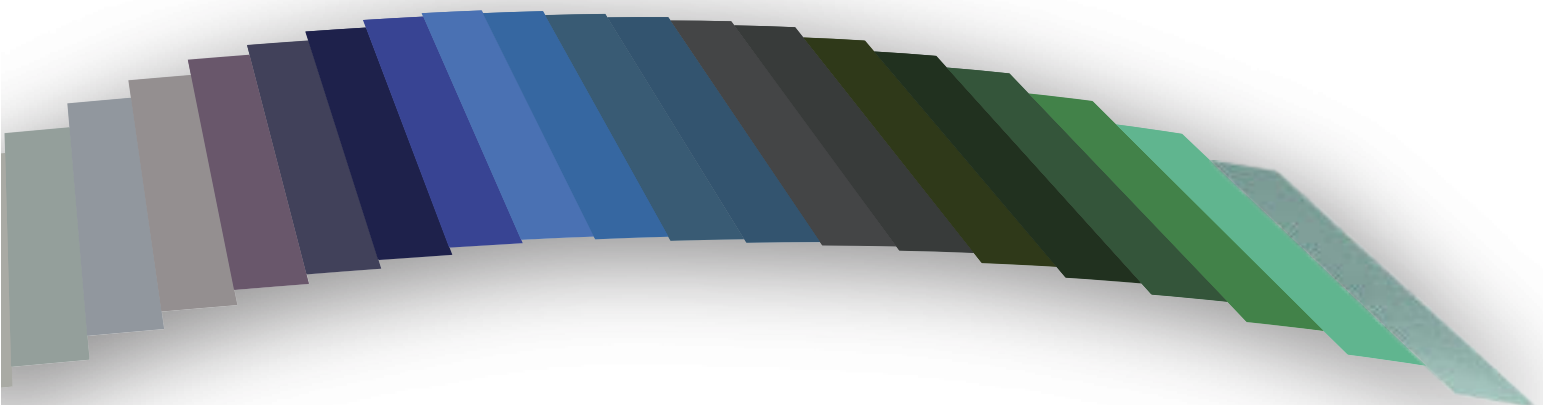
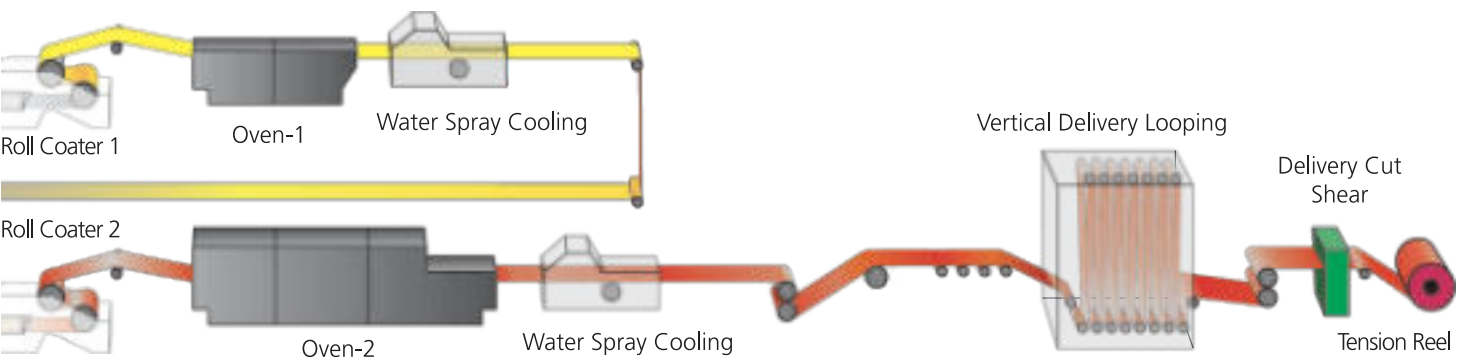

In 2014 Fumira installed a modern Continuous Color Line to increase capacity and expand product variety and quality. With this modern line, Fumira has the ability to use many basic raw materials such as zinc-coated steel sheet (GI), galvalume, stainless steel, aluminum, titanium, copper and magnesium alloy steel. The Continuous Color Line also allows more types of paint to be applied in this modern line, such as polyester, polyurethane and polyvinylidene fluoride (PVDF). This capability has enhanced Fumira as one of the best manufacturers of color coated products with a wide range of products and types of base materials.

COLORCOAT® is a Fumira color product made from polyester which is resistant to abrasion from rainwater, wind and dust. The right choice for tropical climates. Available in various color options.

COLORFRESH® is a Fumira color product made from polyurethane which is resistant to extreme weather. Has its own cleaning power. Available in a variety of color variations.

COLORGRIP® is a Fumira color product based on polyvinylidene difluoride (PVDF) which has perfect resistance to fading and chalking with a shine that is maintained for a long time. Available in a variety of color variations.

Pada tahun 2014 Fumira telah memasang Continuous Color Line yang modern untuk meningkatkan kapasitas serta memperluas variasi produk dan kualitas. Dengan line modern ini, Fumira memiliki kemampuan menggunakan banyak bahan baku dasar seperti lembaran baja lapis seng (GI), galvalume, stainless steel, aluminium, titanium, tembaga dan baja paduan magnesium. Continuous Color Line juga memungkinkan lebih banyak jenis cat yang dapat diaplikasikan dalam line modern ini, seperti polyester, polyurethane dan polyvinylidene fluoride (PVDF). Kemampuan ini telah meningkatkan Fumira sebagai salah satu produsen terbaik dari produk lapis warna dengan berbagai macam produk dan jenis bahan dasar.

COLORCOAT® merupakan produk warna Fumira dengan bahan dasar polyester yang tahan terhadap abrasi air hujan, angin, dan debu. Pilihan tepat untuk iklim tropis. Tersedia dalam berbagai pilihan warna.

COLORFRESH® merupakan produk warna Fumira dengan bahan dasar polyurethane yang tahan terhadap cuaca ekstrim. Memiliki daya bersih sendiri. Tersedia dalam berbagai macam variasi warna.

COLORGRIP® merupakan produk warna Fumira dengan bahan dasar polyvinylidene difluoride (PVDF) yang memiliki ketahanan sempurna dari kepudaran dan pengapuran dengan kilapan yang tetap terjaga dalam waktu lama. Tersedia dalam berbagai macam variasi warna.

Fumira provides a cast concrete retaining floor called the easy-to-handle Compodeck-680 (680 mm effective width) and the economical Compodeck-1000 (1000 mm effective width). Compodeck-680 is a unique cast concrete retaining floor with a bird's tail profile that will clamp when there is a load, while the Compodeck-1000, which is not only equipped with reinforcement and tight embossing, also has a wave profile with an angle of inclination designed to press against the concrete when loaded.

Base material | Material dasar

Material : Hot Dip Galvanized Steel Sheet

- Quality : FumiraGrip Lockforming Quality Guaranteed bending test 0 (zero) T
- Standard : JIS G3302 - SGC550, ASTM A653 Structural Steel Grade 550
- Spangle : Regular Spangle
- Coating : Z.20 -Z-27
- Yield Strength : Min 550 MPa
- Tensile Strength : Min 570 MPa

Compodeck-680



COMPODECK Advantage

- One way positive reinforcement.
- Use as permanent formwork.
- Function as ceiling.
- Shorten construction time.
- Increase safety of construction works.
- Easy installation on structural steel concrete frame construction and masonry wall construction.
- Saves all cost of work especially on concrete volume.

SIFAT PENAMPANG/SECTIONAL PROPERTIES

Thickness (mm)		Unit Weight		Moment of Inertia
SNI BJLS BMT	TCT	Kg/m ²	Kg/m ²	I (mm ⁴ /m)
0.70	0.75	5.28	7.65	4.44 x 10 ⁵
0.80	0.85	6.00	8.70	5.06 x 10 ⁵
1.00	1.05	10.82	8.14	6.28 x 10 ⁵

1. Installation at steel construction

Put the Compodeck panel at the steel beam and adjust the position so that the end panel is overlapped with the steel beam at minimum of 50 mm.

The end of panel can be welded to the steel beam at maximum distance of 340 mm for every weld point across the panel width.

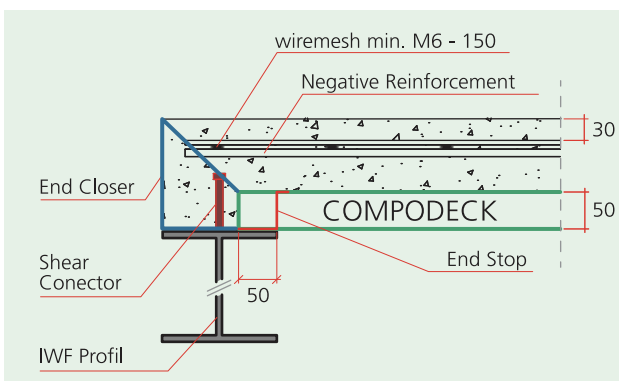

Fumira menyediakan lantai penahan beton cor yang disebut Compodeck-680 (lebar efektif 680 mm) yang mudah ditangani dan Compodeck-1000 yang ekonomis (lebar efektif 1000 mm). Compodeck-680 adalah lantai penahan beton cor unik dengan profil ekor burung yang akan menjepit ketika ada beban, sedangkan Compodeck-1000, selain dilengkapi dengan tulangan dan embossing yang ketat, juga memiliki profil gelombang dengan sudut kemiringan yang dirancang saling menekan beton saat dibebani.

Compodeck-1000



Keunggulan COMPODECK

- Penguatan (tulangan) positif searah.
- Digunakan sebagai rangka kerja tetap (Bekisting tetap).
- Berfungsi sebagai plafon.
- Mempercepat waktu pekerjaan.
- Meningkatkan keamanan kerja.
- Mudah dipasang pada konstruksi baja beton dan bata merah.
- Penghematan biaya konstruksi khususnya volume beton.

SIFAT PENAMPANG/SECTIONAL PROPERTIES

Thickness (mm)		Unit Weight	Moment of Inertia
SNI BJLS BMT	TCT	Kg/m ² = Kg/m ²	I (mm ⁴ /m)
0.70	0.75	7.04	4.06 x 10 ⁵
0.80	0.85	8.00	4.60 x 10 ⁵
1.00	1.05	9.91	5.6 x 10 ⁵

Note :

- Compodeck plate with thickness more than 1.00 mm BMT and length more than 12 m please contact PT FUMIRA.
- Untuk pelat COMPODECK dengan ketebalan lebih dan BMLS 100 dan panjang lebih dari 12 m, harap menghubungi PT FUMIRA.
- TCT : Total Coating Thickness / Tebal Lapisan Total

1. Pemasangan pada konstruksi baja

Tempatkan panel Compodeck pada balok baja dan atur posisinya sehingga tumpang tindih ujung panel dengan balok baja minimum 50 mm.

Ujung panel dapat dilas ke palang baja pada jarak maksimum 340 mm untuk setiap titik las di bagian lebar panel.

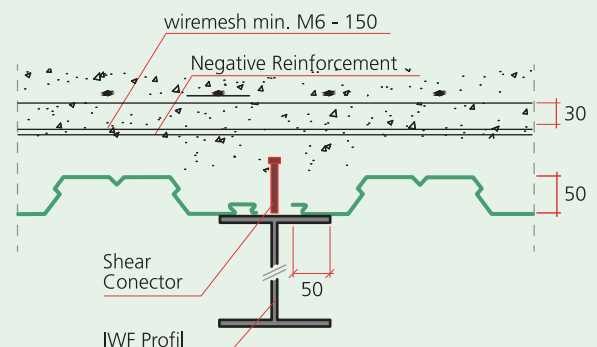

2. Installation on concrete beam

Put the CompoDeck panel at the concrete beam and adjust the position so that the end panel is overlapped with the concrete beam at minimum of 30 mm. If the concrete construction is a T beam, then the panel is put as a single span which its ends are supported by the beams. But if the concrete beams have been made, anchors should be inserted in the beams to suport the panel as a long continuous span.

2. Instalasi pada balok beton

Tempatkan panel CompoDeck pada balok beton dan atur posisinya sehingga tumpang tindih ujung panel dengan balok beton minimum 30 mm. Jika konstruksi beton adalah palang T, maka panel diletakkan sebagai rentang tunggal yang ujung-ujungnya didukung oleh balok. Tetapi, apabila balok beton telah dibuat, jangkar harus ditanam dalam balok untuk menyokong panel sebagai bentangan panjang yang berkesinambungan.

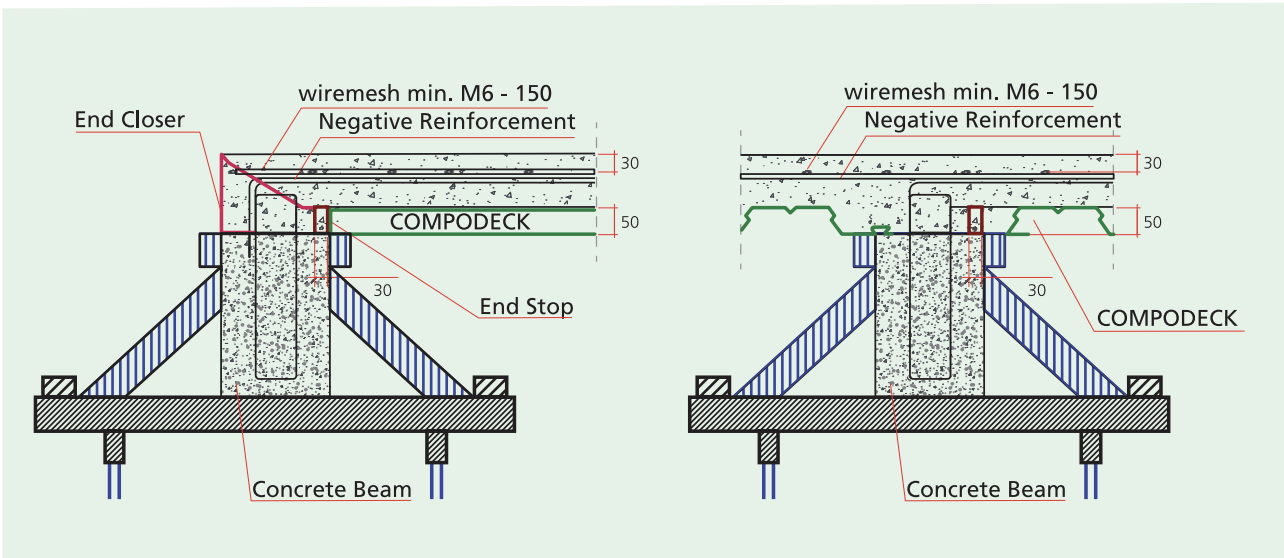

3. Installation on masonry wall

Put the CompoDeck panel at the "rollag" and adjust the position so that the end panel is overlapped with the "rollag" at minimum of 70 mm width. The end of the panel can be fastened to the "rollag" using anchors or concrete nail.

3. Pemasangan pada konstruksi dinding bata

Tempatkan panel CompoDeck pada "Rollag" dan atur posisi sehingga ujung panel tumpang tindih dengan "Rollag" minimum selebar 70 mm. Ujung panel dapat diikat ke "Rollag" menggunakan jangkar atau paku beton.

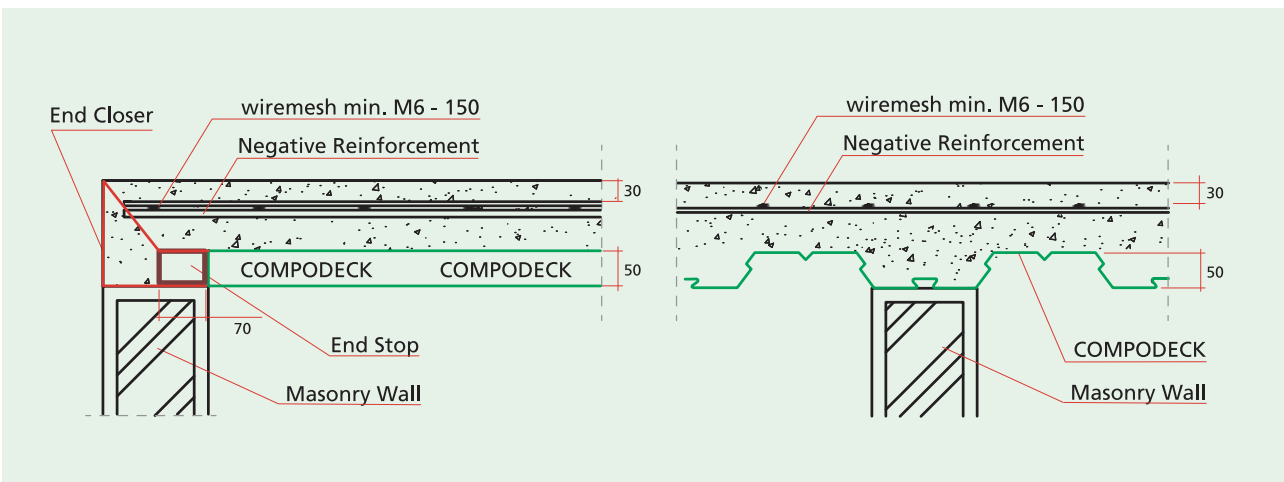

Concreting | Pengecoran

Temporary supports are needed to prevent the Compodeck panel from deflection during concreting until the curing is finished.

The concrete must have a minimum compressive strength of 210 kg/cm² or 21 Mpa after 28 days of concreting. Any additive in the concrete must not contain elements that harmful to the galvanized sheet. It is recommended to use ready mixed concrete for the concreting.

Boards are recommended as the walk way for worker and wheelbarrows during the concreting.

Important: Spread the concrete during the concreting to avoid an excessive load at one point due to the accumulation of concrete.

The secondary reinforcement bars are placed at about 20 mm from the surface of the Compodeck panel and the concrete must be thoroughly compacted between the bars until the required slab thickness is evenly reached.

The backside of the Compodeck panel profile can be exposed as the decorative ceiling barely or painted with attractive colors (Colordeck). Ceiling sheet material can be attached to the back side of Compodeck panel using anchors which are placed before the concreting or hangers which are placed at the ribs of panel.

Penyokong sementara diperlukan untuk mencegah panel Compodeck dari lendutan selama pengecoran hingga pengerasan selesai. Beton harus memiliki kuat tekan minimum 210 kg/cm² atau 21 Mpa setelah 28 hari dari pengecoran. Setiap bahan imbuhan yang dimasukan kedalam beton tidak boleh mengandung unsur-unsur yang berbahaya bagi lembar galvanis. Direkomendasikan untuk menggunakan beton yang telah siap untuk pengecoran.

Disarankan menggunakan papan untuk tempat berjalan bagi pekerja dan gerobak selama pengecoran tersebut.

Penting: Sebarkan beton selama pengecorannya untuk menghindari beban berlebih pada satu titik karena akumulasi coran beton.

Batang penguat sekunder (tulangan susut) ditempatkan sekitar 20 mm diatas permukaan panel Compodeck dan beton harus dipadatkan seksama diantara batang penguat sampai ketebalan slab yang diperlukan tercapai dengan merata.

Bagian belakang profil panel Compodeck dapat diperlihatkan sebagai langit-langit dekoratif tanpa dicat atau dicat dengan warna-warna yang menarik (Colordeck). Bahan lembaran langit-langit dapat dipasang pada sisi belakang panel Compodeck menggunakan jangkar yang ditempatkan sebelum pengecoran atau penggantung yang ditempatkan di tulangan panel.

Effective span | Bentang efektif

The optimal Compodeck panel length are two to three spans distance in one sheet. The gap between the ends of panel should be as small as possible. Along the overlapped sides of panels should be fastened in every 0,5 m using a 5 mm diameter of rivet or self drilling screw (10 x 16 mm, S point hexagonal or wafer head). The shear connector to hold the lateral load should have a maximum diameter of 20 mm and height of 40 mm.

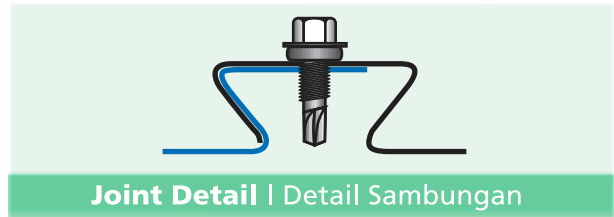

Joint Detail | Detail Sambungan

Panjang optimal panel Compodeck adalah dua hingga tiga kali jarak bentang dalam satu lembar. Celah antara ujung panel harus sekecil mungkin. Sepanjang tumpang tindih sisi panel harus dikeling di setiap 0,5 m menggunakan keling berdiameter 5 mm atau sekrup *self drilling* (10 x 16 mm, S titik heksagonal atau *wafer head*). *Shear connector* untuk menyokong beban lateral harus memiliki diameter maksimum 20 mm dan tinggi 40 mm.

Composite plate effective span table

Tabel bentang efektif pelat komposit

FUMIRAGRIP®

Span Type	Single Span			Double Span			Continuous Span		
	COMPODECK			COMPODECK			COMPODECK		
	0.7	0.8	1.0	0.7	0.8	1.0	0.7	0.8	1.0
BMT									
100	2120	2190	2310	2450	2760	2910	2300	2590	2730
110	2060	2130	2260	2390	2680	2840	2240	2520	2660
120	2020	2090	2200	2330	2620	2770	2190	2460	2600
130	1980	2040	2160	2280	2570	2710	2140	2410	2550
140	1940	2000	2120	2240	2520	2660	2100	2360	2500
150	1900	1970	2080	2200	2470	2610	2060	2320	2450
160	1870	1940	2050	2160	2430	2570	2030	2280	2410
170	1840	1910	2010	2130	2390	2530	2000	2250	2370
180	1820	1880	1980	2100	2360	2490	1970	2210	2340
190	1790	1850	1960	2070	2320	2450	1940	2180	2310
200	1770	1830	1930	2040	2040	2420	1920	2150	2280

FUMIRA projects | Proyek-proyek FUMIRA

Industrial

Industri



Danone Aqua Plant Pandaan, Sukorejo
Product Type : G-680



PT Cheil Abrasive Indonesia, Cikarang
Product type : GG-750



PLTU Tanjung Balai, Karimun
Product Type : A-735

Commercial

Komersial



Pasar Induk Kramat Jati
Product Type : SF-750



Pasar Muntlani, Magelang
Product type : GG-750

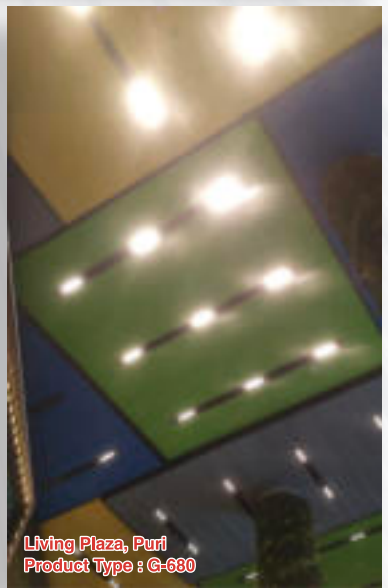

Living Plaza, Puri
Product Type : G-680

Residential

Perumahan



The Signature Cluster, Modernland, Cakung
Product Type : Click-330



Alia Residence, Tangerang
Product Type : Click-330



Ganesha Cluster, Telaga Kahuripan, Bogor
Product type : Click-330

FUMIRA projects | Proyek-proyek FUMIRA

Facilities

Fasilitas



Masjid Sido Muncul, Semarang
Product Type : L-700



Lapangan Sepak Bola Tehbotol AYO Arena, Bogor
Product Type : G-680



Summit Auto Group (SAG) Learning Center, Rancamaya
Product type : GG-750



Stadron Udara 31 Halim Perdanakusuma, Jakarta
Product type : G-680



Truck Wing Box
Product type : B-832



Stasiun Malang I Product type : GG-750



Gedung Workshop Politeknik Balikpapan
Product type : GG-750



PT Pamapersada, Cileungsi
Product type : Compodeck-680



Balai Purnomo Prawiro Universitas Indonesia
Product type : BL-600

Transportation

transportasi

Education & Office

Pendidikan dan Perkantoran

Click-330 Roofing – Minimalist roofing system

Click-330 adalah produk atap yang memiliki profile gelombang rendah untuk bentang pendek hingga menengah tanpa sambungan dengan cara pemasangan *boltless* menggunakan sistem **click**. **Click-330** merupakan salah satu produk atap Fumira paling terbaru dengan rancangan minimalis untuk memenuhi kebutuhan profil atap *boltless* yang mudah ditangani dan dipasang.

Keunggulan **Click-330** :

- Rancangan minimalis.
- Bebas lubang yang terpapar dengan pemasangan sistem click.
- Mudah dalam penanganan dan pemasangan.
- Profil rendah yang ekonomis.
- Kapasitas tampung curah hujan hingga 100 mm/jam.
- Dapat dibongkar pasang tanpa merusak material atap.

Profil gelombang yang minimalis

Profil gelombang dan ukuran **Click-330** terutama ditujukan untuk atap dengan kemiringan diatas 5° sehingga walaupun berbentuk minimalis, produk **Click-330** tetap dapat menahan curah hujan tinggi tanpa terjadi kebocoran.

Click-330 memiliki 5 variasi profil gelombang dan dapat dibuat bentuk lengkung dengan minimum diameter 4,5 m.

Click-330 is a roofing product that has low wave profile for continuous short to medium spans by way of of boltless mounting of click system. **Click-330** is one of the most recent Fumira roof product with minimalist design to meet the demand of boltless roof profile for that easy to be handled and installed.

Click-330 advantages:

- Minimalist design.
- Non-exposed mounting hole with click system.
- Easy in handling and installation.
- Economical low wave profile.
- Capacity disposed of rainfall up to 100 mm / hour.
- Can be reassembled without damaging the roof material.

Minimalist wave profile

Wave profile and the size of the **Click-330** is mainly purposed for more than 5° of roof slope so that instead of minimalist shape, **Click-330** products can still with hold high enough rainfall flow capacity without any leakage.colors with gloss (glossy) .

Click-330 has 5 wave profiles variation and they can be curved shape with diamater of 4.5 m minimum.

Wave profile of Click-330

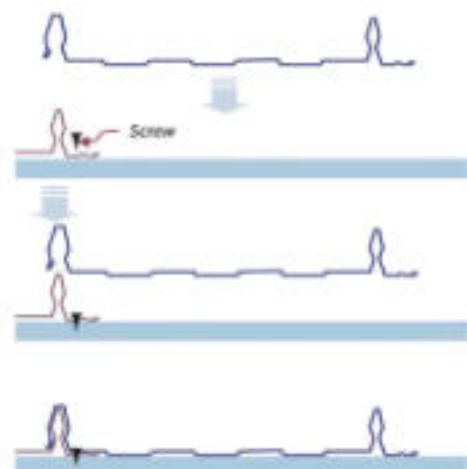
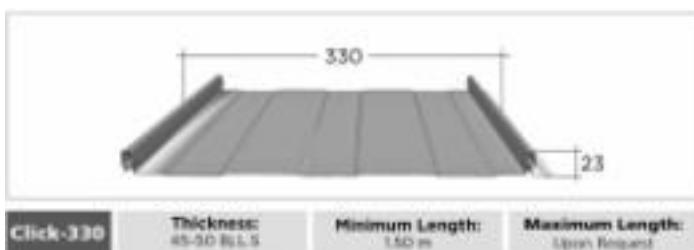

Sectional properties table

Thickness(mm)		Unit weight		Momen of Inersia
SNI Symbol BjLSBMT	Total Coating Thickness	Kg/m	Kg/m ²	1 x (cm ⁴ /m)
0.45	0.50	1.72	3.78	3.19
0.50	0.55	1.90	4.17	4.22

BL-600

Long span roof | Atap bentang panjang

BL-600 advantages

- Hole free, 100% leak proof.
- Have a minimum 1° (one degree) slope.
- Roof support line up to 4.00m.
- Rain withhold capacity up to 600mm/hour.
- Construction width can be more than 100 m.
- Can be installed and uninstalled without damaging material.

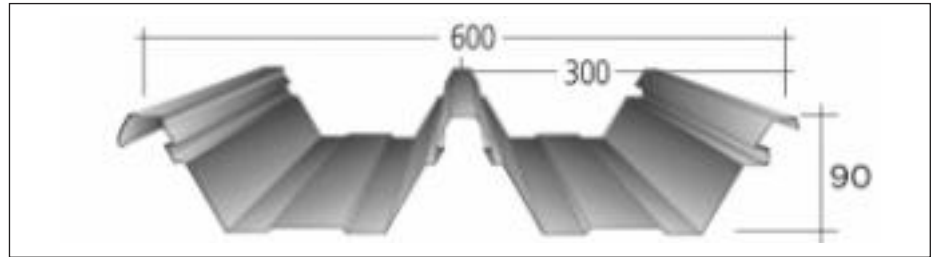

BL-600	Thickness: 45-80 B ₁ L ₅	Minimum Length: 1.50 m	Maximum Length: 12 m
---------------	--	----------------------------------	--------------------------------

Keunggulan BL-600

- Bebas lubang, anti bocor 100%.
- Sudut kemiringan minimal 1° (satu derajat).
- Jarak gording hingga 4,00 m.
- Kapasitas tampung curah hujan hingga 600mm/jam.
- Bentang bangunan bisa lebih dari 100 m.
- Dapat dibongkar-pasang tanpa merusak material.

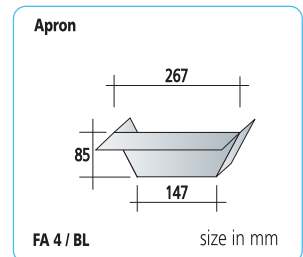
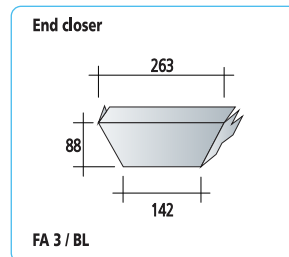
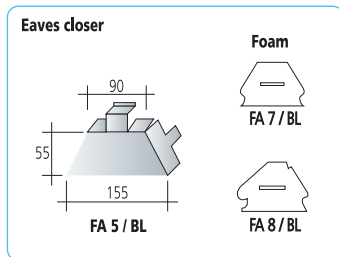
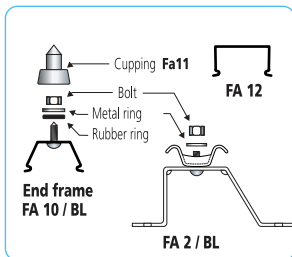
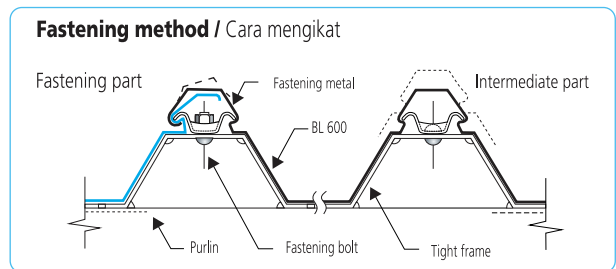
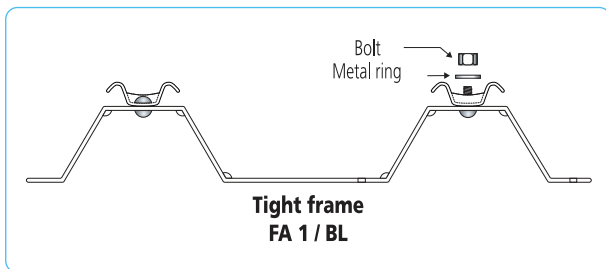
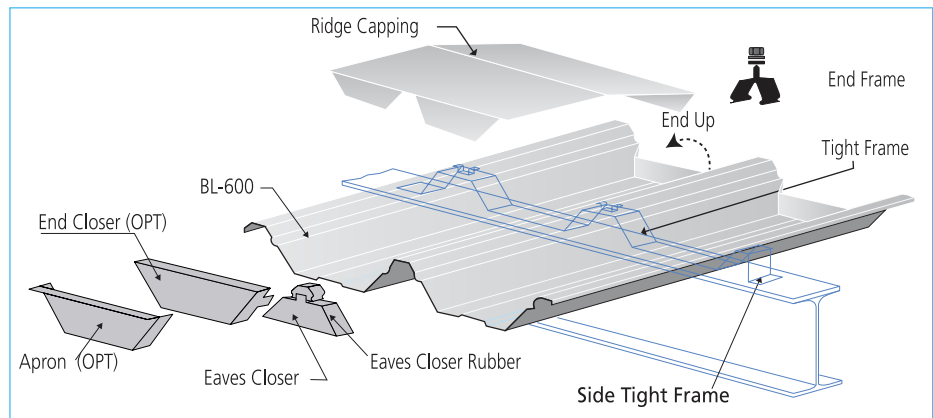

Thickness (mm)		Unit weight		Moment of inertia	Section modulus
SNI B ₁ LS BMT	TCT	kg/m	kg/m ²	I x (cm ⁴ /m)	Z x (cm ³ /m)
0.45	0.50	3.39	5.65	101	19
0.60	0.65	4.49	7.48	130	17
0.80	0.85	5.92	9.86	166	21

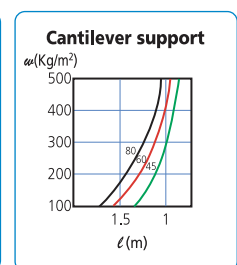
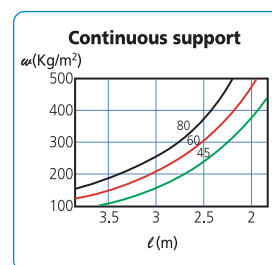
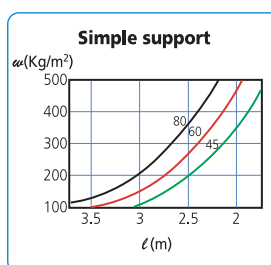

SF-650

Long span roof | Atap bentang panjang

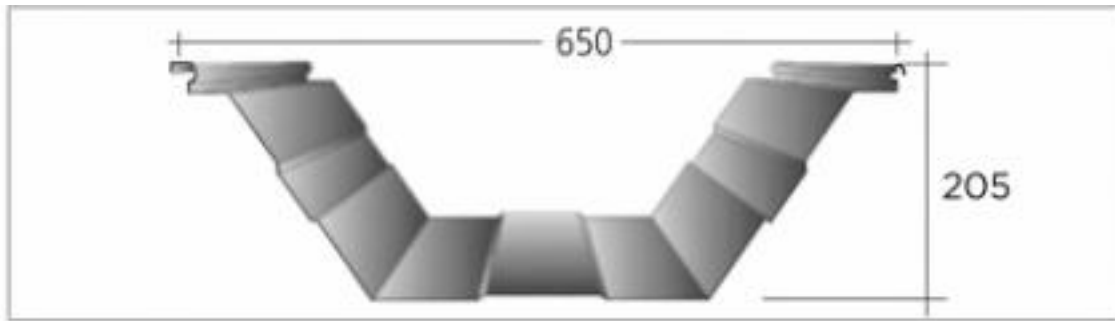

SF-650	Thickness: 45 Bj.L.S	Minimum Length: 150 m	Maximum Length: 12 m
---------------	--------------------------------	---------------------------------	--------------------------------

Seaming system | Sistem seaming

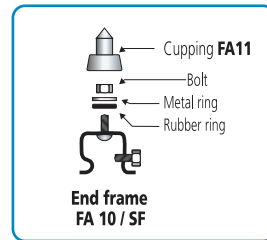
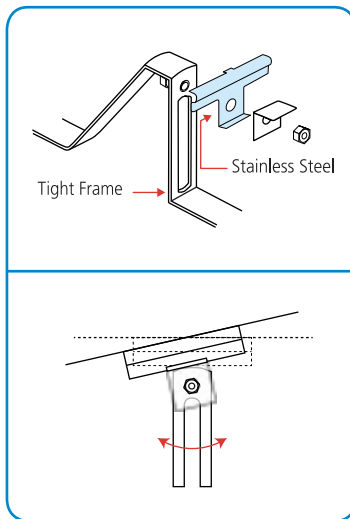
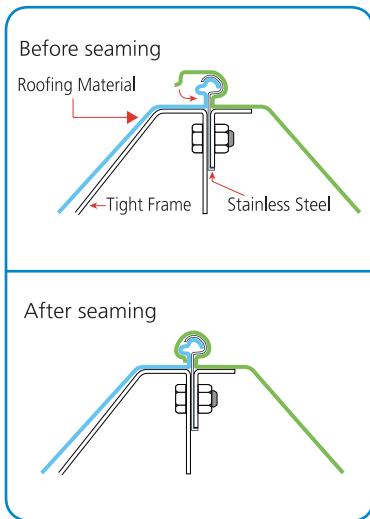

Hand tool

Sectional properties | Sifat penampang

Thickness (mm)		Unit weight		Moment of inertia	Section modulus
SNI BjLS BMT	TCT	(kg/m ¹)	(kg/m ²)	I x (cm ⁴ /m)	Z x (cm ³ /m)
0.45	0.50	3.39	5.65	222	24.3

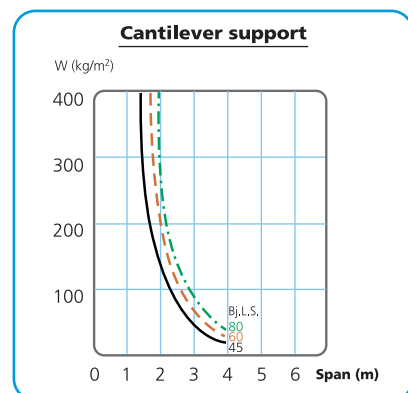
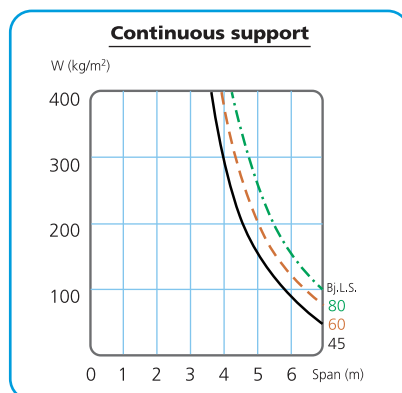
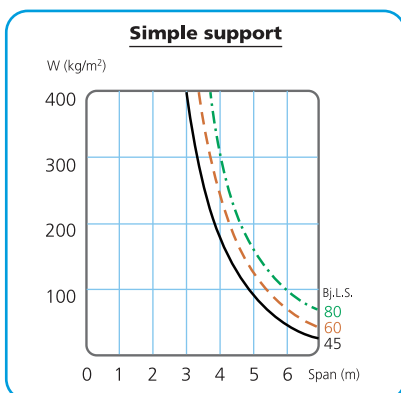

SF-750

Long span roof | Atap bentang panjang

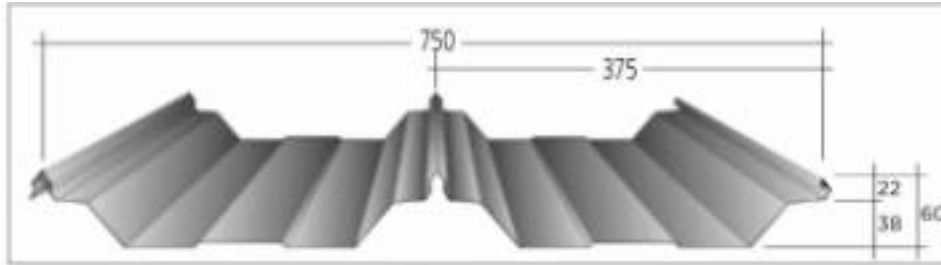

SF-750	Thickness: 45-60 Bj.L.S	Minimum Length: 1.50 m	Maximum Length: 12 m
---------------	-----------------------------------	----------------------------------	--------------------------------

Thickness (mm)		Unit weight		Moment of inertia	Section modulus
SNI BjLS BMT	TCT	(kg /m ¹)	(kg /m ²)	I x (cm ⁴ /m)	Z x (cm ³ /m)
0.45	0.50	3.39	4.52	18.79	4.494
0.50	0.55	3.75	5.00	20.67	4.943
0.60	0.65	4.49	5.99	24.74	5.932

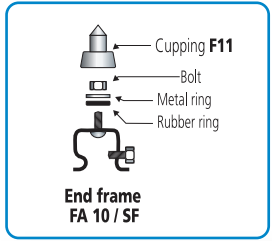
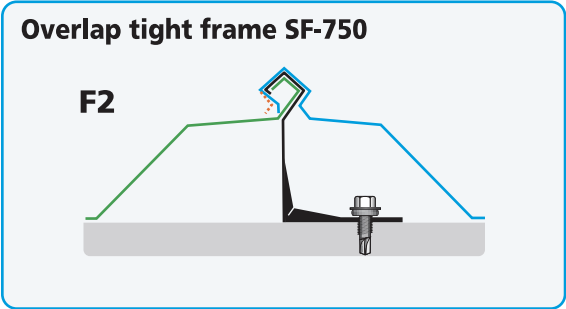
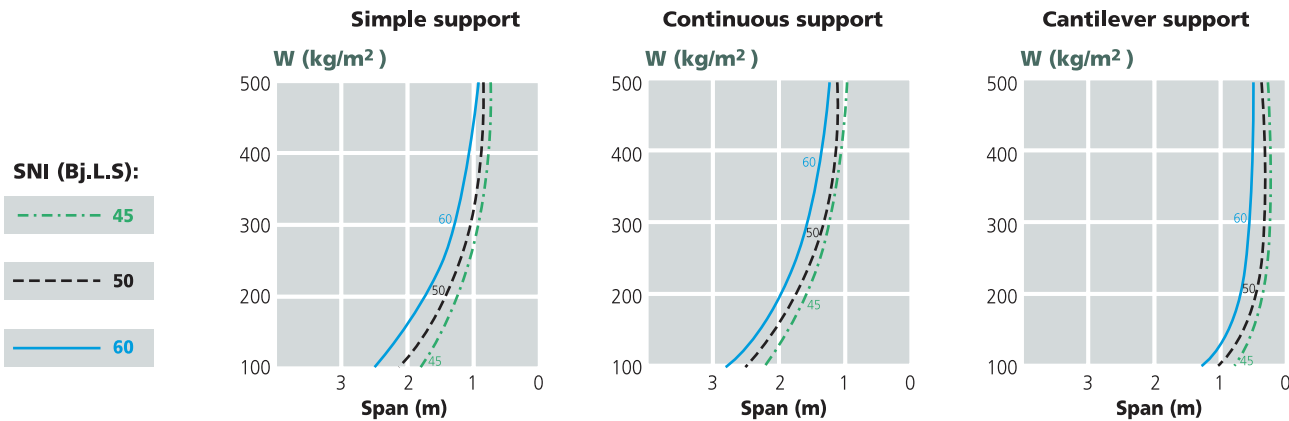

Seaming Machine

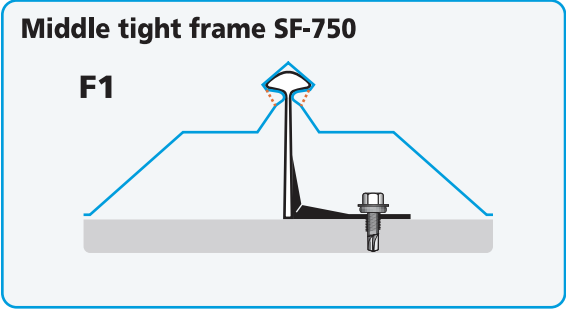

Hand tool

I-600

Long Span Roof | Atap Bentang Panjang

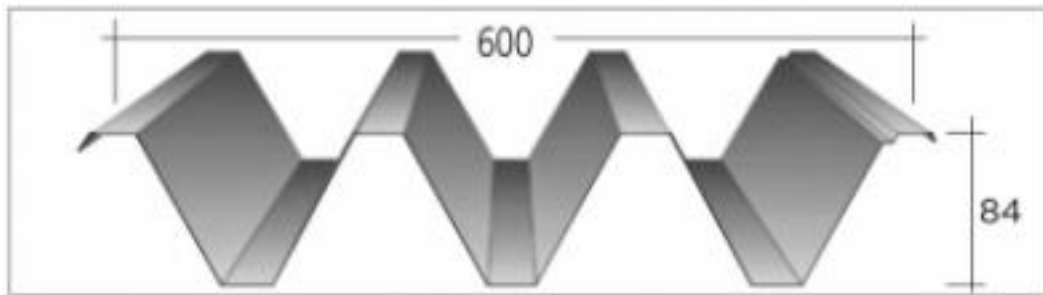

I-600	Thickness: 45-60 B _{JLS}	Minimum Length: 1.50 m	Maximum Length: 12 m
--------------	---	----------------------------------	--------------------------------

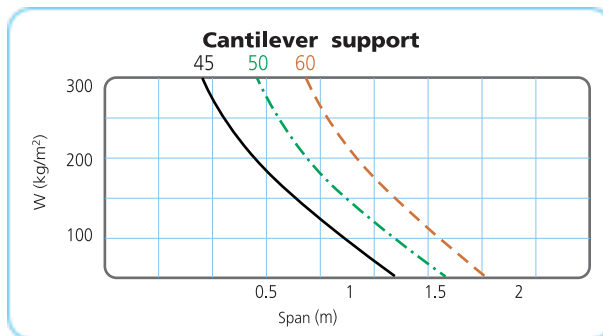
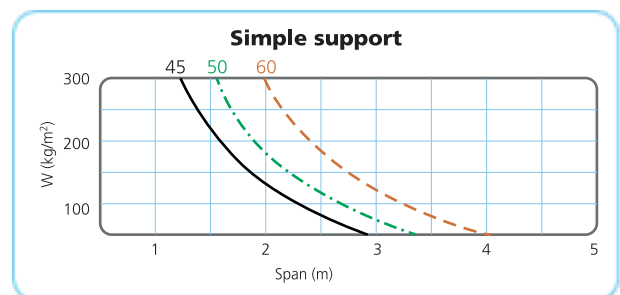
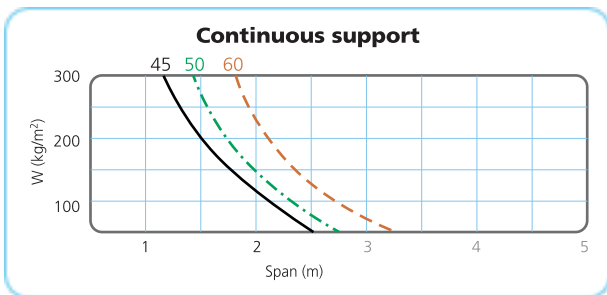

Thickness (mm)		Unit weight		Momen of inertia	Section modulus
SNI B _{JLS} BMT	(TCT)	(Kg/m)	(Kg/m ²)	I x (mm ⁴ /m)	Z x (mm ⁴ /m)
0.45	0.50	3.39	5.65	16.80	3.62
0.50	0.55	3.75	6.25	23.80	5.14
0.60	0.65	4.49	7.48	37.80	8.17

Tight frame	Side tight frame	End closer	Apron	Eaves closer
FA 1/I	FA 2/I	FA 3/I	FA 4/I	FA 5/I

size in mm

GP-550

Long span roof | Atap bentang panjang

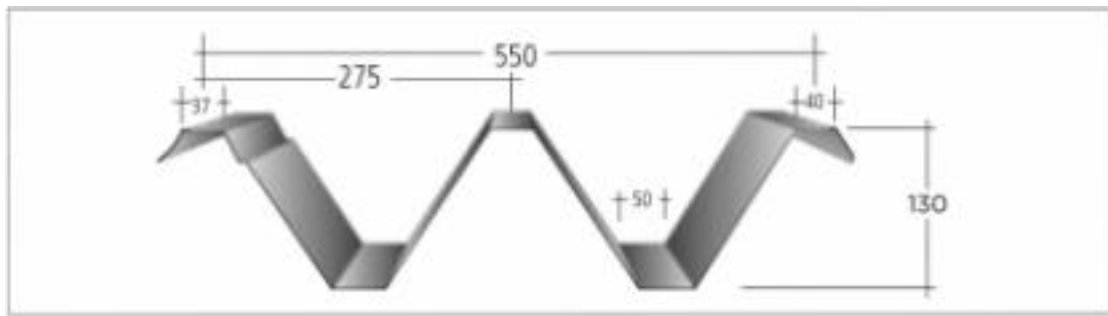

GP-550	Thickness: 45-80 B _J L.S	Minimum Length: 1.50 m	Maximum Length: 12 m
---------------	---	----------------------------------	--------------------------------

Size in mm

Continuous support & Cantilever support

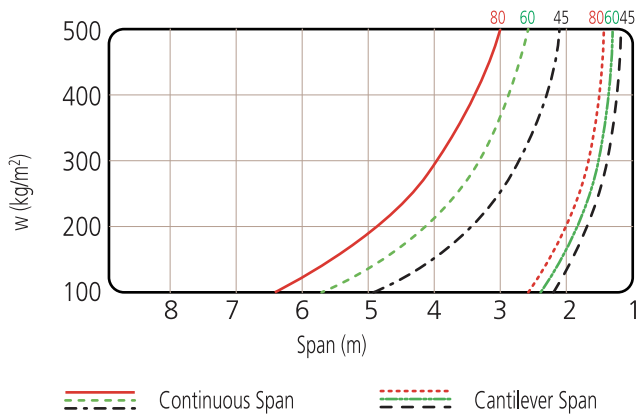

Simple support

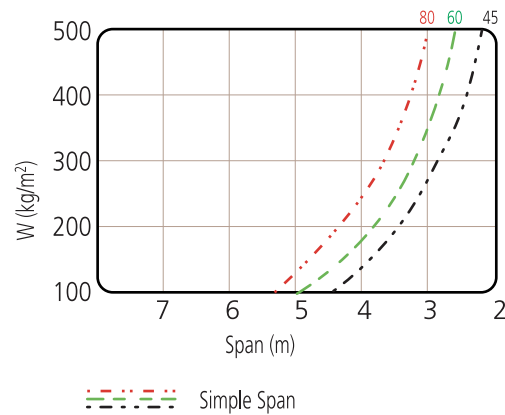

Thickness (mm)		Unit weight		Momen of inertia I_x (cm ⁴ /m)	Section modulus Z_x (cm ³ /m)
SNI B _J LS BMT	TCT	(Kg/m)	(Kg/m ²)		
0,45	0.50	3.39	6.16	159.0	22.6
0,60	0.65	4.49	8.16	213.0	30.3
0,80	0.85	5.92	10.76	285.0	40.5

Tight frame	Side tight frame	End closer	Apron	Eaves closer
FA 1 / GP	FA 2 / GP	FA 3 / GP	FA 4 / GP	FA 5 / GP

Size in mm

BL-710

Middle span roof | Atap bentang menengah

BL-710 Advantages

- Originally Fumira modern design.
- Hole free Push Lock installation system.
- Easy in installation
- Economic wide profile.
- Can be installed and uninstalled without damaging material.

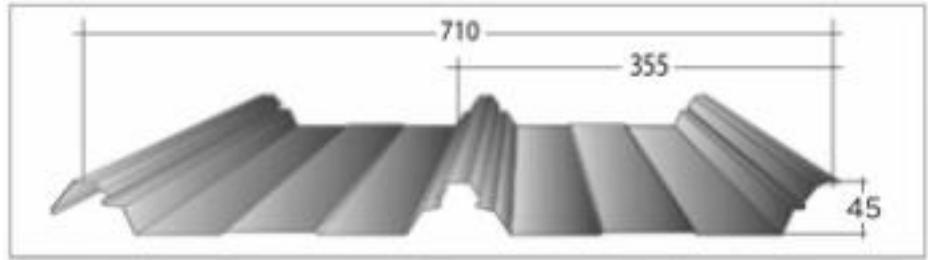

BL-710	Thickness: 45-60 Bl.L.5	Minimum Length: 150 m	Maximum Length: 12 m
---------------	-----------------------------------	---------------------------------	--------------------------------

Keuntungan BL-710

- Rancangan modern original dari Fumira.
- Bebas lubang dengan pemasangan sistem Push Lock.
- Mudah dalam instalasi
- Profil lebar yang ekonomis.
- Dapat dibongkar-pasang tanpa merusak material.

Thickness (mm)		Unit Weight		Moment of Inertia I_x (mm ⁴ /m)
ENI BL.L.5 BHT	TCT	(kg/m)	(kg/m ²)	
0.45	0.50	3.39	4.77	9.08
0.60	0.65	3.76	5.28	10.07
0.60	0.65	4.49	6.33	12.04

(*khusus galvanis polos min. 0,45 BMT)

Push-lock system

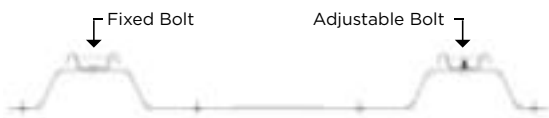

Push-lock system



Simple Support

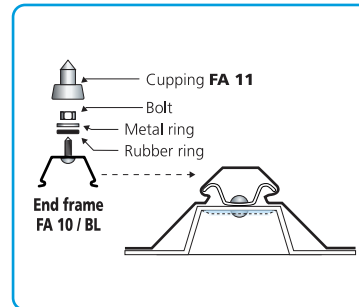
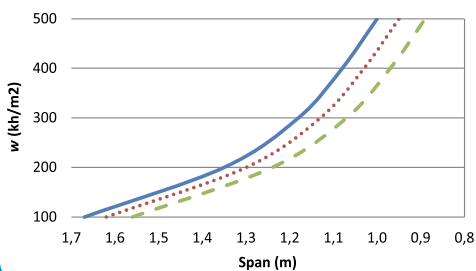

Continuous Support

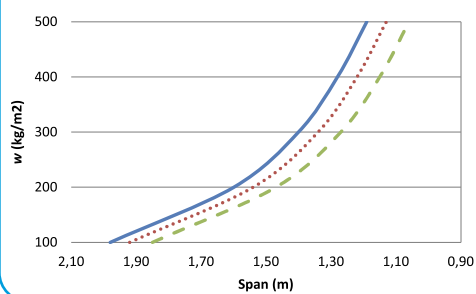

Cantilever Support

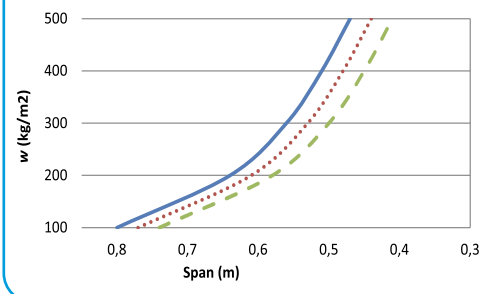

Middle span roof | Atap bentang menengah

FUMIRASPAN advantages:

1. Economical width.
2. Trapezoidal wave profile with adequate ribs enforcement.
3. Wave profile combination that provides decorative value.
4. Easy and cheap in installation by using screw without special tightframes.
5. Metal coated steel material that can be customized color coating.

Keunggulan FUMIRASPAN:

1. Lebar yang ekonomis.
2. Profil gelombang trapezoidal dan dengan tulangan penguat yang memadai
3. Kombinasi profil gelombang yang memberikan nilai derkoratif.
4. Pemasangan yang mudah dan murah menggunakan sekrup tanpa pengikat khusus
5. Material baja lapis logam yang dapat diberi lapisan warna yang sesuai.

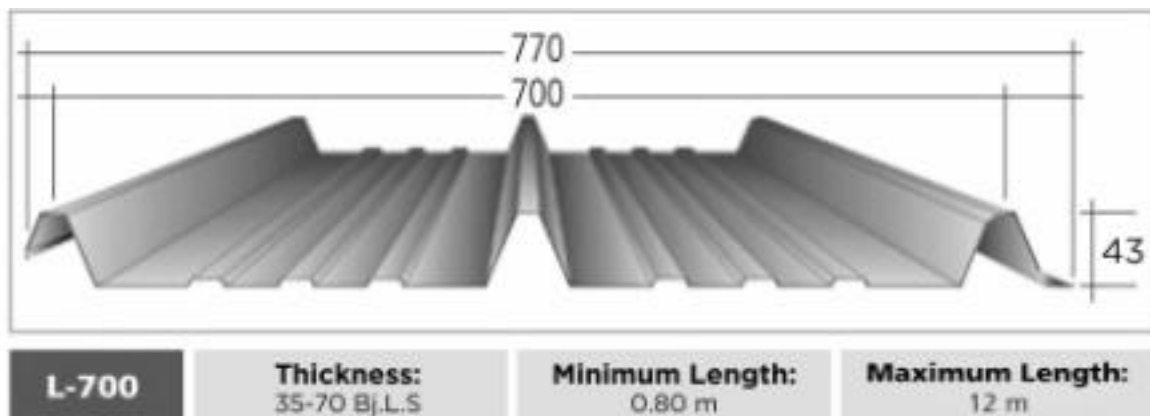

Note / Catatan:

For length more than 1 2.00 m or job-site corrugating, please contact Fumira.

Untuk panjang lebih dari 12,00 m atau penggelombangan di lokasi proyek, harap menghubungi FUMIRA.

Sectional properties | Sifat penampang

Thickness (mm)		Unit weight		Moment of inertia I_x (cm ⁴ /m)	Section modulus Z_x (cm ³ /m)	Support spacing		
SNI BjLS BMT	TCT	(Kg/m ¹)	(Kg/m ²)			Intermediate spans (m)	End spans (m)	Overhang (m)
0.35	0.40	2.64	3.77	5.0	2.08	1.45	1.15	0.30
0.40	0.45	3.03	4.33	6.0	2.50	1.70	1.30	0.40
0.45	0.50	3.39	4.84	7.0	2.95	1.80	1.40	0.50
0.50	0.55	3.75	5.36	8.1	3.40	1.90	1.50	0.60
0.60	0.65	4.49	6.41	10.6	4.40	2.00	1.60	0.70
0.70	0.75	5.21	7.44	13.32	5.40	2.10	1.70	0.75

Installation | Pemasangan

Preparation

The end result of roof installation is influenced by the preparation. Good preparation will make the job of roof installation safe and easy.

Safety

Safety is very important in roof installation. Wind, rain, heat and lightning are factors that influence the roof installation safety. Roof installation is a job at height, open air and exposed to the rain, wind, sun heat and lightning. Use proper safety equipments such as safety net, safety helmet, body harness, gloves, sun glasses and non slippery footwear. Wear full body cover clothes to prevent sun heat. Never do the installation when there is rain fall, strong windy or lightning.

Wind direction

Determine the wind direction during the rainy season. The roof should be installed against the wind direction.

Roof frame

Makesure that the roof frame are well painted and free from dirt, bulges and remained object from the previous works that could harmful to the roof sheet.

Fastener

Make sure to use the galvanized or chromed coating screws to fasten the roof. Use the screws with rubber made of washer to prevent the screw scratching the roof and make sure that the washer diameter is bigger than the screw head.

Persiapan

Hasil akhir dari instalasi atap dipengaruhi oleh persiapan. Persiapan yang baik akan membuat pekerjaan instalasi atap yang aman dan mudah.

Keselamatan

Keselamatan sangat penting dalam instalasi atap. Angin, hujan, panas dan petir merupakan faktor yang mempengaruhi keselamatan instalasi atap. Instalasi atap adalah pekerjaan di ketinggian, udara terbuka dan terkena hujan, angin, panas matahari dan petir. Gunakan peralatan keselamatan yang tepat seperti jaring pengaman, helm pengaman, pengikat tubuh, sarung tangan, kacamata gelap dan alas kaki yang tidak licin. Kenakan pakaian penutup tubuh secara penuh untuk mencegah panas matahari. Jangan melakukan instalasi ketika ada hujan, angin kencang atau petir.

Arah angin

Tentukan arah angin ketika musim hujan. Atap harus dipasang berlawanan arah dengan angin.

Rangka atap

Pastikan bahwa rangka atap telah dicat dengan baik dan bebas dari kotoran, tonjolan dan benda sisa dari pekerjaan sebelumnya yang bisa berbahaya bagi lembaran atap.

Pengikat

Pastikan untuk menggunakan sekrup yang dilapis galvanis atau chrome untuk mengikat atap. Gunakan sekrup dengan ring yang terbuat dari karet untuk mencegah sekrup menggores atap dan pastikan bahwa diameter ring lebih besar dari kepala sekrup.

Installation Process | Proses Pemasangan

Placing on roof frame

Lift up and put the roof sheets on the roof frames piled and tied. Keep the lower and upper ribs side of roof sheets facing to the same direction. The weight of every pile of roof sheets laid on the roof frames must not exceed the roof frame load capacity and piled in accordance to the required quantity of the column or section.

Installation steps

The air circulation monitor section is the start point of installation for building equipped with this facility and the gutter section must be finished prior to roof installation. The first roof sheet is laid on where its upper rib is at the edge of building and the lower rib is at the other side. The second roof sheet is laid on at the side of the first roof sheet where its upper rib overlaps the lower rib of the first roof sheet and so on for the next roof sheets.

For large building, some joins of roof sheets might be needed to extend the length of the roof sheets. To avoid worker stepping on the installed roof, the installation should follow the installation procedure, i.e., after the row A is filled up, then row B, C and so on until all the rows are filled up evenly in the same day. Workers are commonly prohibited to step on and walk on the installed roof during the installation of next roof sheets.

Penempatan di atas rangka atap

Angkat dan tempatkan lembaran atap pada rangka atap ditumpuk dan diikat. Tetapkan rusuk bagian bawah dan bagian atas sisi lembar atap menghadap ke arah yang sama. Berat setiap tumpukan lembaran atap yang diletakkan pada rangka atap tidak boleh melebihi kapasitas beban rangka atap dan ditumpuk sesuai dengan jumlah yang dibutuhkan kolom atau bagiannya.

Tahap pemasangan

Bagian monitor untuk sirkulasi udara adalah titik awal dari instalasi untuk bangunan yang dilengkapi dengan fasilitas ini dan bagian talang harus diselesaikan sebelum instalasi atap. Lembar Atap pertama diletakkan dengan rusuk atasnya berada di tepi gedung dan rusuk bawah di sisi lain. Lembar atap kedua diletakkan pada di sisi lembar atap pertama di mana rusuk atasnya menumpang tindih tulang rusuk bawah dari lembar atap pertama dan seterusnya untuk lembaran atap berikutnya.

Untuk bangunan besar, beberapa sambungan lembar atap mungkin diperlukan untuk memperpanjang panjang lembaran atap. Untuk menghindari pekerja menginjak atap yang telah terpasang, instalasi harus mengikuti prosedur instalasi, yaitu, setelah baris A diisi, kemudian baris B, C dan seterusnya sampai semua baris yang terisi secara merata di hari yang sama. Secara umum pekerja dilarang untuk menginjak dan berjalan di atap yang telah terpasang selama pemasangan lembar atap berikutnya.

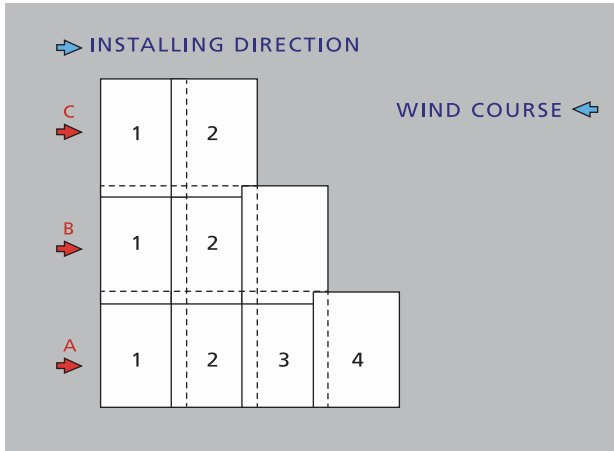

Installation of simple wave profile roof / Instalasi atap profil gelombang sederhana

Walking on Roof

It is recommended to use wooden planks as a walking way for workers on the roof. Some roof profile types allow workers to step on and walk along the installed roof. Worker could walk on the peaks of the small corrugated types, such as G-680 and C-710 with minimum base material thickness of 0.45 mm, where they have to step on three peaks of the corrugated sheet at the same time. While for the bigger profile type, such as BL-600, SF-750 and SF-650, with minimum base material thickness of 0.45 mm, worker could walk on along the valley of profiles.

Joint

If necessary, joints can be made for roofing product with simple wave profiles, such as the C-710, C-750, A-750, G-680. The width direction joint of the corrugated roofing sheets need only one wave of overlap, while the length direction joining need overlap of 200 mm. If the roof angel is less than 5°, the joining need overlaps of 300 mm and leakproof sealant is required.

Drilling Holes

An electric drill or screwdriver is needed to make holes for fastener and screws. The steel chips residue from the drilling should be cleaned immediately as it may cause rust stain on the roof surface. Chisel or nail are not recommended to make holes as it may lead to roof leaks and further damage in the future.



Berjalan di atas atap

Disarankan untuk menggunakan papan kayu sebagai jalan bagi pekerja di atas atap. Beberapa jenis profil atap memungkinkan pekerja untuk menginjak dan berjalan di sepanjang atap yang telah terpasang. Pekerja bisa berjalan pada puncak dari jenis bergelombang kecil, seperti G-680 dan C-710, dengan minimum ketebalan bahan dasar 0,45 mm, di mana mereka harus menginjak tiga puncak dari lembar bergelombang secara bersamaan. Sedangkan untuk jenis profil yang lebih besar, seperti BL-600, SF-750 dan SF-650, dengan minimum ketebalan bahan dasar 0,45 mm, pekerja dapat berjalan di sepanjang lembah profil.

Sambungan

Jika diperlukan, sambungan dapat dibuat untuk atap dengan profil gelombang sederhana, seperti C-710, C-750, A-750, G-680. Sambungan arah lebar dari lembaran atap bergelombang hanya memerlukan tumpang tindih satu gelombang, sementara sambungan arah panjang memerlukan tumpang tindih 200 mm. Jika sudut atap kurang dari 5°, memerlukan tumpang tindih sambungan 300 mm dan diperlukan perekat anti bocor.

Pembuatan Lubang

Bor listrik atau obeng dibutuhkan untuk membuat lubang untuk pengikat dan sekrup. Serpihan baja sisa dari pengeboran harus segera dibersihkan karena dapat menyebabkan noda karat pada permukaan atap. Pahat atau paku tidak disarankan untuk membuat lubang karena dapat menyebabkan kebocoran atap dan kerusakan lebih lanjut di kemudian hari.

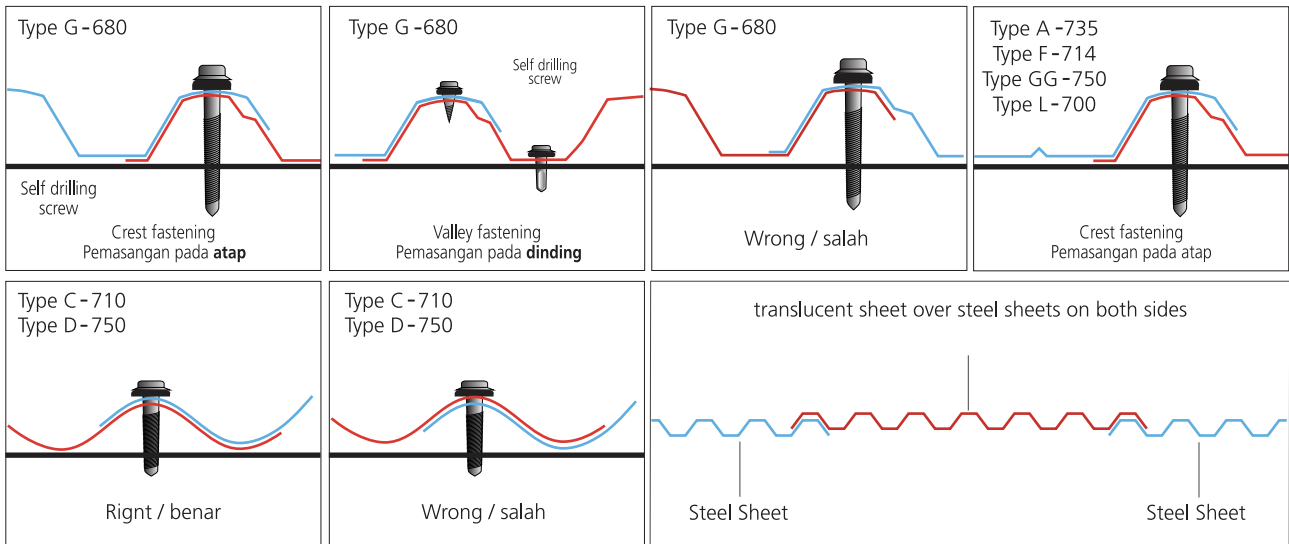

Flashing standard | Standar nok

<p>1. Standard Flashing</p> <p>Code: F 1 Size: 450mm x 4m</p>		<p>5. Transverse Flashing</p> <p>Code: F 5 Size: 300mm x 4m</p>	
<p>2. Corner Flashing</p> <p>Code: F 2 Size: 300mm x 4m</p>		<p>6. Parapet or End Wall Flashing</p> <p>Code: F 6 Size: 300mm x 4m</p>	
<p>3. Corner Flashing</p> <p>Code: F 3 Size: 300mm x 4m</p>		<p>7. End Wall Transverse Flashing</p> <p>Code: F 7 Size: 300mm x 4m</p>	
<p>4. Longitudinal Flashing</p> <p>Code: F 4 Size: 300mm x 4m</p>		<p>8. Fascia Capping</p> <p>Code: F 8 Size: 300mm x 4m</p>	

For non standard shape and size of roof flashing order please contact **FUMIRA**.
Untuk pesanan bentuk dan ukuran penutup atap tidak standar harap menghubungi **FUMIRA**.

Size in mm

Storage | Penyimpanan

In Covered Space

Roof sheets should be stored in a dry and ventilated place in either covered storage or other covered space away from rain, dust, soil and dirt. Roof sheets should not be laid directly on floor by using proper wedges such as wooden or rubber pallets. The roof sheets must not be stored in the same place with corrosive chemical agents that will damage the roof sheet. Any wet roof sheet should be wiped and dried before storage.

Di Ruang Tertutup

Lembaran atap harus disimpan di tempat yang kering dan berventilasi baik penyimpanan di gudang tertutup atau ruang tertutup lainnya yang terhindar dari hujan, debu, tanah dan kotoran. Lembaran atap tidak boleh diletakkan langsung di lantai dengan cara menggunakan ganjal yang sesuai seperti palet kayu atau karet. Lembaran atap tidak boleh disimpan di tempat yang sama dengan bahan kimia yang bersifat korosif yang dapat merusak lembaran atap. Setiap lembar atap yang basah harus dilap dan dikeringkan sebelum penyimpanan.

In Open Space

Roofing sheets storage in open space should be done in a way to avoid rain, dust and dirt. The roof sheets pile should be in a slope to avoid puddles and wet roof sheets must be wiped and dried prior to storage. Roofing sheet piles should not be in direct contact with soil, dirt, garbage and puddles. Try to pile on a dry place and higher than the surroundings to avoid puddles when it rains. Piles should be covered with canvas or other waterproof material. Lift the canvas cover by long bar when storing on unsealed floor to ensure good air circulation.

Plan the works accordingly to avoid storage of roofing sheets in the open air for too long. This will reduce the risk of damage due to rain, humidity, dents from hard objects, dust and soil, and so forth. Further more, black or white spots may appear on the roof sheet surface if the sheet are left in the open air for a long period.

Di Ruang Terbuka

Penyimpanan lembaran atap di ruang terbuka dilakukan dengan cara menghindarkannya dari hujan, debu dan kotoran. Tumpukan harus miring agar tidak terjadi genangan air dan lembaran atap yang basah harus dilap dan dikeringkan sebelum penyimpanan. Tumpukan lembaran atap tidak boleh bersentuhan langsung dengan tanah, kotoran, sampah dan genangan air. Usahakan penumpukan di tempat yang kering dan lebih tinggi dari sekitarnya untuk menghindari genangan air jika hujan. Tumpukan harus ditutup dengan terpal atau bahan anti air lainnya. Angkat terpal penutup menggunakan batang yang panjang pada saat penyimpanan diatas lantai yang tidak tertutup untuk memastikan sirkulasi udara yang baik.

Rencanakan pekerjaan dengan seksama untuk menghindari penyimpanan lembaran atap di udara terbuka terlalu lama. Hal ini akan mengurangi resiko kerusakan karena hujan, kelembaban, lekukan karena benda keras, terkena debu dan tanah dan lain sebagainya. Lebih jauh lagi, noda hitam atau putih dapat muncul pada permukaan lembaran atap apabila lembaran tersebut ditinggalkan di udara terbuka untuk jangka lama.

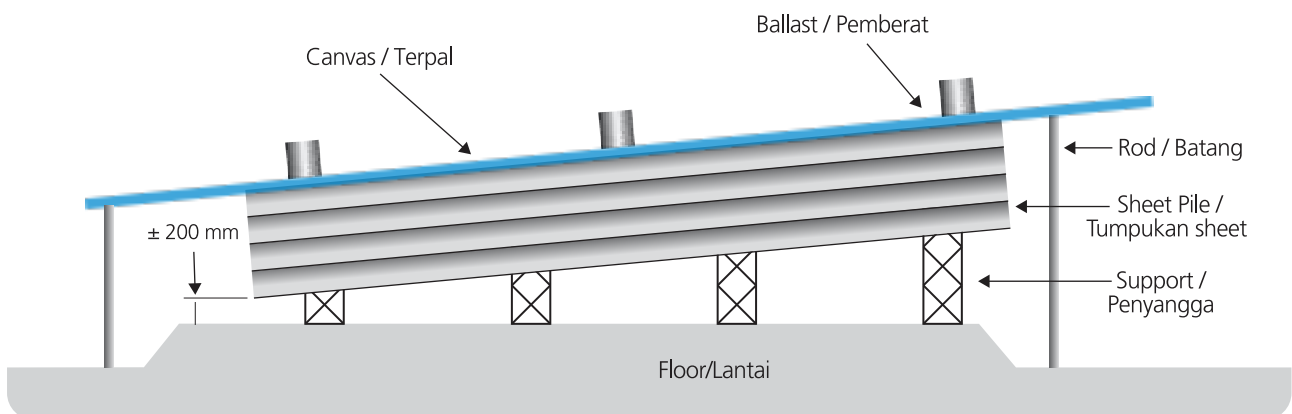

Cleaning | Pembersihan

Clean the roof sheet surface from remaining nails, rivets, wires, and other metal chips (especially metal residue from drilling activity) during the installation. Clean again at the end of each day of installation to avoid rust stain on the roof sheet surface.

Roof sheet surface have to be cleaned also from the workers shoes mark, hand and footprint which will bring bad impression of the roof sheets.

Bersihkan permukaan lembaran atap dari sisa paku, keling, kabel, dan serpihan logam lainnya (terutama sisa logam dari kegiatan pengeboran) selama instalasi. Bersihkan lagi pada akhir setiap hari instalasi untuk menghindari noda karat pada permukaan lembar atap. Permukaan lembar atap harus dibersihkan juga dari bekas tapak sepatu, jejak tangan dan kaki yang akan membawa kesan buruk dari lembaran atap.

Quality Standard | Standart Kualitas

FUMIRA is committed to meeting product quality requirements, so since the product was first marketed commercially in 1998, Fumira has received the Indonesian National Standard certificate for zinc-coated sheet steel products (SNI 07-2053). Furthermore, starting in 2003, to improve company performance, with the commitment of top management, as well as all employees, FUMIRA has carried out a program to implement the ISO 9001:2000 Quality Management System which was subsequently upgraded to ISO 9001:2008 at the end of 2010 and began implementing ISO 9001 : 2015 at the end of 2015. In 2021 FUMIRA also received TKDN certification with a total of up to 58%, this is clear evidence of Fumira's commitment to supporting the Regulation of the Minister of Industry of the Republic of Indonesia regarding increasing the use of domestic products. Most recently, FUMIRA has also received a Green Label certificate as a form of Fumira's support for environmental sustainability. This is clear evidence that PT. FUMIRA always tries to make improvements for customer satisfaction in accordance with FUMIRA's vision and mission.

FUMIRA memiliki komitmen untuk memenuhi persyaratan mutu produk, maka sejak pertama produk dipasarkan secara komersial pada tahun 1998, Fumira telah mendapatkan sertifikat Standar Nasional Indonesia untuk produk baja lembaran lapis seng (SNI 07-2053). Selanjutnya, permulaan tahun 2003, untuk meningkatkan kinerja perusahaan, dengan komitmen manajemen puncak, serta seluruh karyawan, FUMIRA telah menjalankan program penerapan Sistem Manajemen Mutu ISO 9001:2000 yang selanjutnya ditingkatkan ke ISO 9001:2008 pada akhir tahun 2010 dan mulai menerapkan ISO 9001:2015 pada akhir tahun 2015. Pada tahun 2021 FUMIRA juga mendapatkan sertifikasi TKDN dengan jumlah hingga 58%, hal ini menjadi bukti nyata komitmen Fumira untuk mendukung Peraturan Menteri Perindustrian Republik Indonesia tentang peningkatan penggunaan produk dalam negeri. Terbaru, FUMIRA juga telah mendapatkan sertifikat Green Label sebagai bentuk dukungan Fumira terhadap kelestarian lingkungan. Hal ini merupakan bukti nyata bahwa PT. FUMIRA selalu berusaha melakukan perbaikan untuk kepuasan pelanggan sesuai visi dan misi FUMIRA.



PRODUCTS TYPE

WAVE PROFILE (mm) / PROFIL GELOMBANG (mm)

FUMIRAGRIP, Al - Zn COATED, COLORCOAT, COLORFRESH & COLORGRIP

Roofing Ceiling Siding/Walling Floordeck

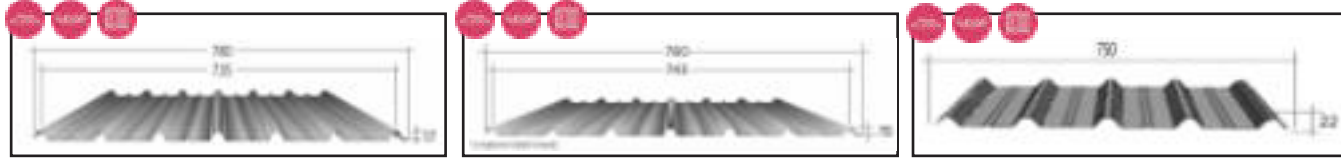

A-735	Thickness: 20-60 Bj.L.S	Minimum Length: 0.80 m	Maximum Length: 12 m	A-750	Thickness:*) 20-25 Bj.L.S	Minimum Length: 0.80 m	Maximum Length: 12 m	GH-750	Thickness: 30-50 Bj.L.S	Minimum Length: 1.50 m	Maximum Length: 12 m
--------------	-------------------------	------------------------	----------------------	--------------	---------------------------	------------------------	----------------------	---------------	-------------------------	------------------------	----------------------

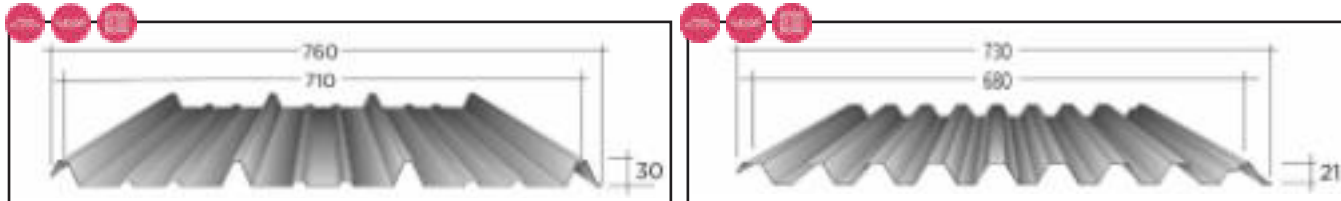

F-714	Thickness: 40-60 Bj.L.S	Minimum Length: 0.80 m	Maximum Length: 12 m	G-680	Thickness: 30-60 Bj.L.S	Minimum Length: 0.80 m	Maximum Length: 12 m
--------------	-------------------------	------------------------	----------------------	--------------	-------------------------	------------------------	----------------------

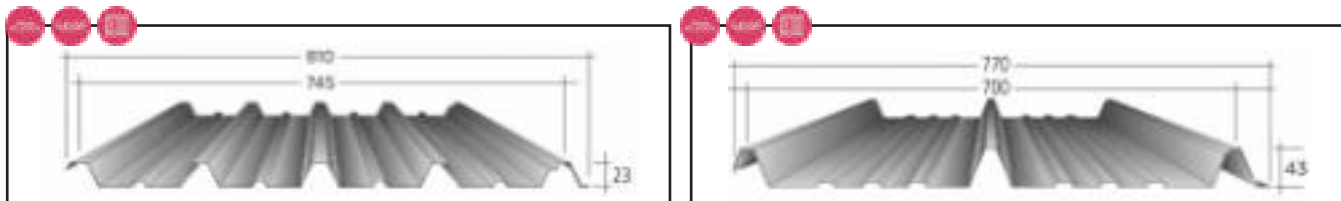

GG-750	Thickness: 30-60 Bj.L.S	Minimum Length: 0.80 m	Maximum Length: 12 m	L-700	Thickness: 35-70 Bj.L.S	Minimum Length: 0.80 m	Maximum Length: 12 m
---------------	-------------------------	------------------------	----------------------	--------------	-------------------------	------------------------	----------------------



Click-330	Thickness: 45-50 Bj.L.S	Minimum Length: 1.50 m	Maximum Length: Upon Request	C-710	Thickness: Hard : 20-30 Bj.L.S Soft : 30-120 Bj.L.S	Minimum Length: 1.50 m	Maximum Length: Hard : 3.65 m (for 20 Bj.L.S) Soft : 3.65 m
------------------	-------------------------	------------------------	------------------------------	--------------	--	------------------------	--

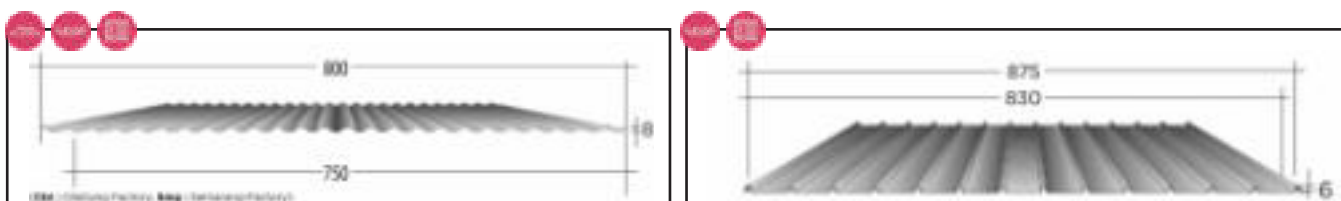

D-750	Thickness: Cbt : 20-30 Bj.L.S Smg : 20-30 Bj.L.S	Minimum Length: Cbt : 1.50 m Smg : 1.50 m	Maximum Length: Cbt : 1.829 m Smg : 3.658 m	Spangle: Cbt : Min Spangle Smg : With Spangle	B-832	Thickness: 20-60 Bj.L.S	Minimum Length: 0.80 m	Maximum Length: 12 m
--------------	---	--	--	--	--------------	-------------------------	------------------------	----------------------

Product with a length more than 12 meter or job-site roll forming, please Contact FUMIRA.
Untuk Pemesanan panjang lebih dari 12 meter atau penggelombang di lokasi proyek, harap menghubungi FUMIRA.

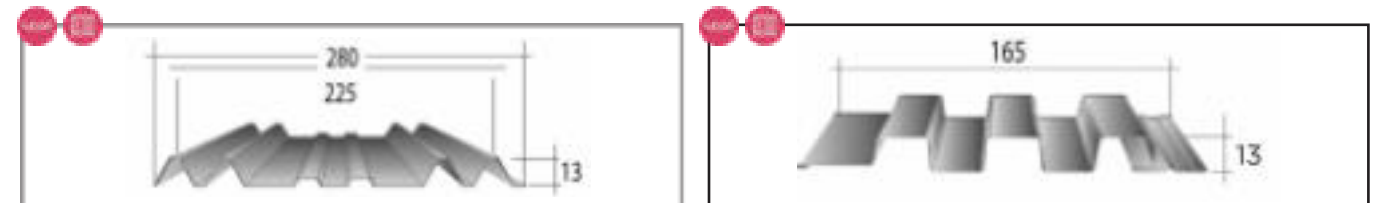

H-225	Thickness: 20-60 Bj.L.S	Minimum Length: 0.80 m	Maximum Length: 5 m
--------------	-------------------------	------------------------	---------------------

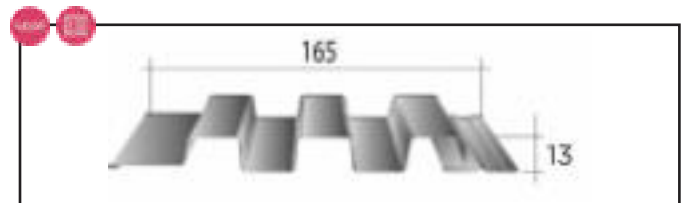

K-165	Thickness: 35-50 Bj.L.S	Minimum Length: 1.50 m	Maximum Length: Upon Request
--------------	-------------------------	------------------------	------------------------------

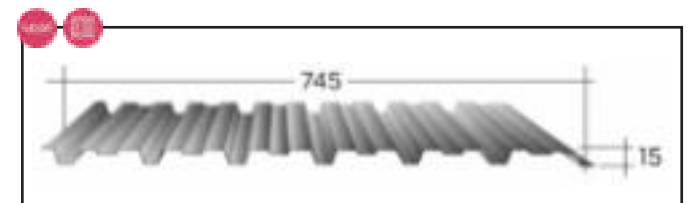

M-750	Thickness: 35-50 Bj.L.S	Minimum Length: 1.50 m	Maximum Length: Upon Request
--------------	-------------------------	------------------------	------------------------------

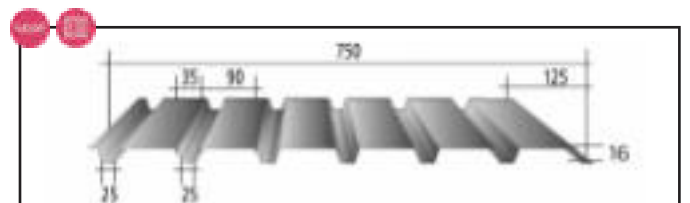

N-750	Thickness: 45-50 Bj.L.S	Minimum Length: 1.50 m	Maximum Length: Upon Request
--------------	-------------------------	------------------------	------------------------------



I-600	Thickness: 45-60 Bj.L.S	Minimum Length: 1.50 m	Maximum Length: 12 m
--------------	-------------------------	------------------------	----------------------

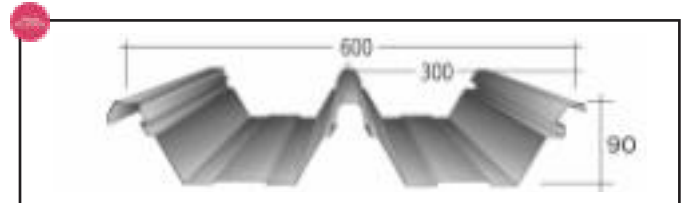

BL-600	Thickness: 45-80 Bj.L.S	Minimum Length: 1.50 m	Maximum Length: 12 m
---------------	-------------------------	------------------------	----------------------

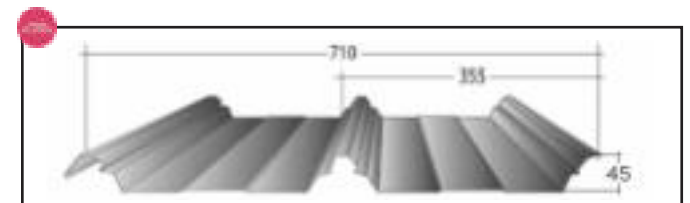

BL-710	Thickness: 45-60 Bj.L.S	Minimum Length: 1.50 m	Maximum Length: 12 m
---------------	-------------------------	------------------------	----------------------

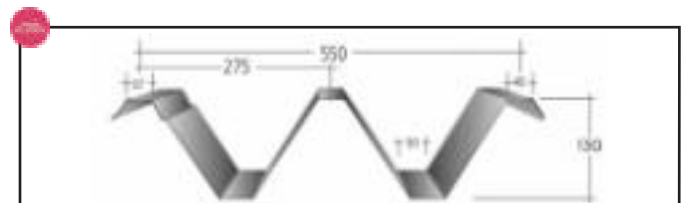

GP-550	Thickness: 45-80 Bj.L.S	Minimum Length: 1.50 m	Maximum Length: 12 m
---------------	-------------------------	------------------------	----------------------

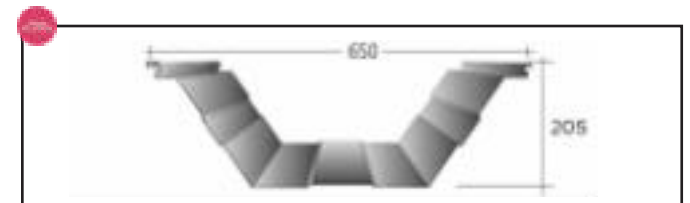

SF-650	Thickness: 45-100 Bj.L.S	Minimum Length: 1.50 m	Maximum Length: 12 m
---------------	--------------------------	------------------------	----------------------

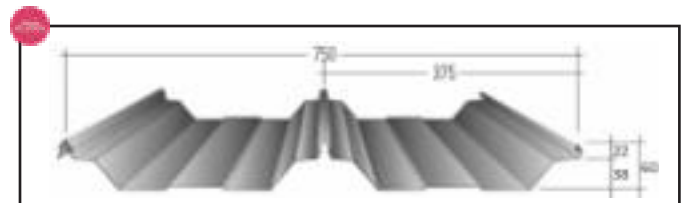

SF-750	Thickness: 45-60 Bj.L.S	Minimum Length: 1.50 m	Maximum Length: 12 m
---------------	-------------------------	------------------------	----------------------

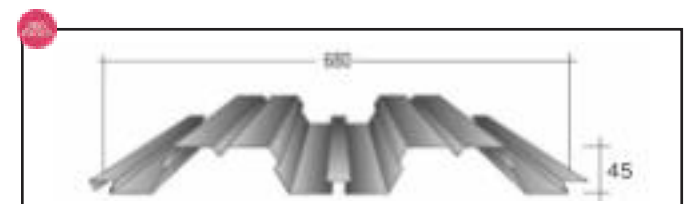

COMPODECK-680	Thickness: 70-100 Bj.L.S	Minimum Length: 1.00 m	Maximum Length: 12 m
----------------------	--------------------------	------------------------	----------------------

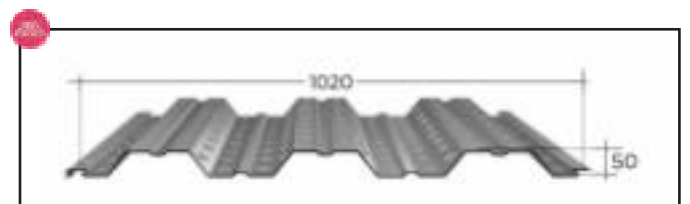

COMPODECK-1000	Thickness: 70-100 Bj.L.S	Minimum Length: 2.00 m	Maximum Length: 12 m
-----------------------	--------------------------	------------------------	----------------------



fumira.co.id

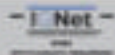
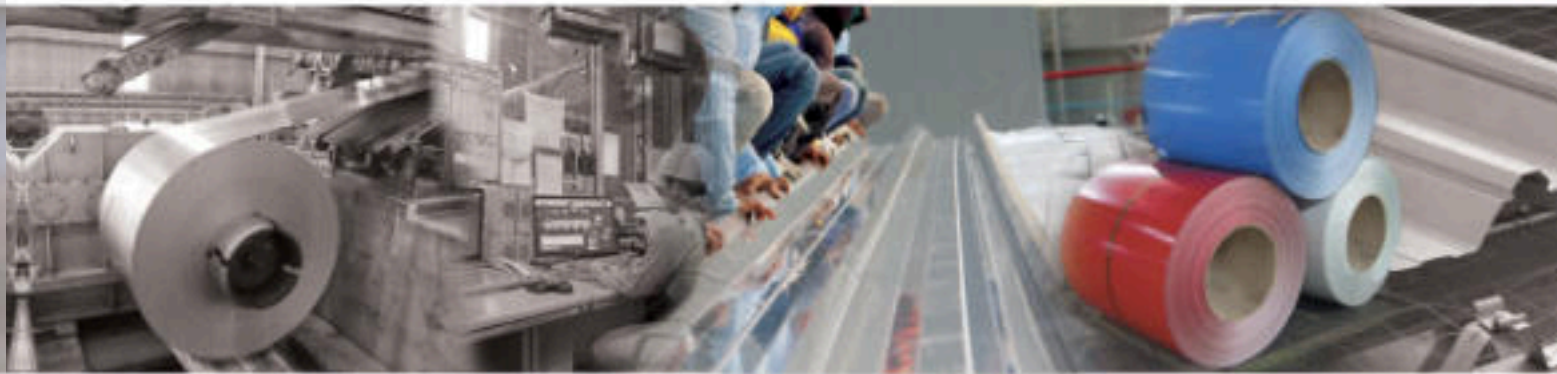

FUMIRA

MAIN OFFICE & JAKARTA FACTORY

Kav. A-1 Bekasi Fajar Industrial Estate, MM2100 Industrial Town, Cibitung, Bekasi 17520 West Java-INDONESIA
Tel : (62-21) 898-0320 (Hunting) Fax : (62-21) 898-1092, 898-1063, 898-1118
Telex : 64830 FUMIRA IA

SEMARANG FACTORY

Jl. Dr. Setiabudi 104 Srandol Timur, Semarang-INDONESIA
Tel : (62-24) 747-4447 (Hunting) Fax : (62-24) 747-2450
Telex : 222817 FUMIRA IA