

FUMIRA[®]
Leading Innovation of Galvanized Steel



FUMIRA GRIP[®]

The Best Zinc Coated Steel Sheet
for Various Applications



FUMIRA GRIP[®]

by FUMIRA[®]

TABLE OF CONTENT

- 1 INTRODUCTION | PENGENALAN
- 2 ADVANTAGES | KEUNGGULAN
- 3 WHY ZINC? | KENAPA ZINC?
- 4 NON-OXIDIZING FURNACE TECHNOLOGY | TEKNOLOGI TUNGKU *NON-OXIDIZING*
- 5 PRODUCT VARIATION | VARIASI PRODUK
- 6 THE MANUFACTURING PROCESS | PROSES MANUFAKTUR
- 8 PRODUCT SPECIFICATION | SPESIFIKASI PRODUK
- 13 WIDE RANGE OF END USAGE VARIATIONS | VARIASI PENGGUNAAN AKHIR YANG LUAS
- 14 PACKAGING & LABELING | PENGEMASAN & PELABELAN
- 16 CERTIFICATION | SERTIFIKASI

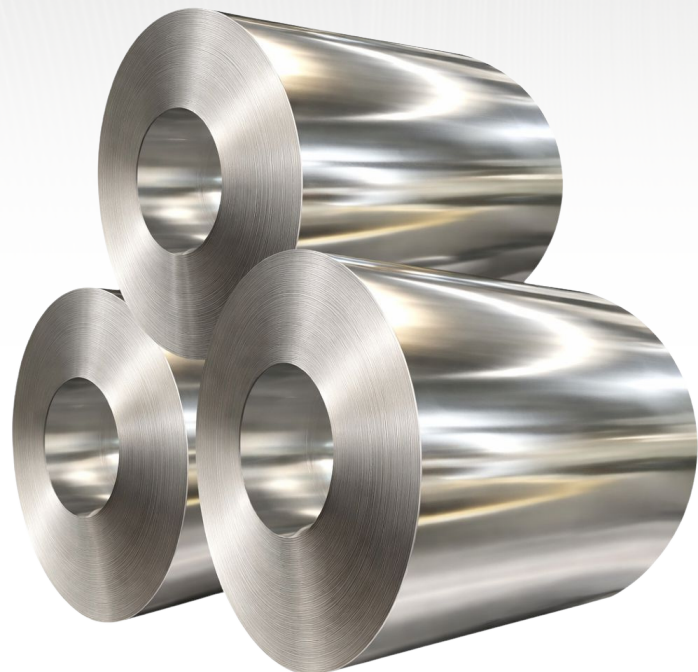

Overview

FUMIRA® is one of the largest producer of galvanized steel sheet in Indonesia. FUMIRA® become the first producer that use Continuous Galvanizing Line (CGL) with Non-Oxidizing Furnace (NOF) system since the operation of the second FUMIRA® factory in Jakarta in the year of 1997. This technology comes from Nippon Steel Corp. Japan. This system produce an excellent Zinc coating quality (lock-forming quality) product, called **FUMIRAGRIP®**, which has bend ability up to 0 (zero) gap thickness without crack nor peeled off based on bending test comply to JIS G3302. This coating quality is ideal for industrial use, particularly in automotive and construction such as oil and air filters, car bodies, steel frames, partition, roof, wall, ducting and floordeck.

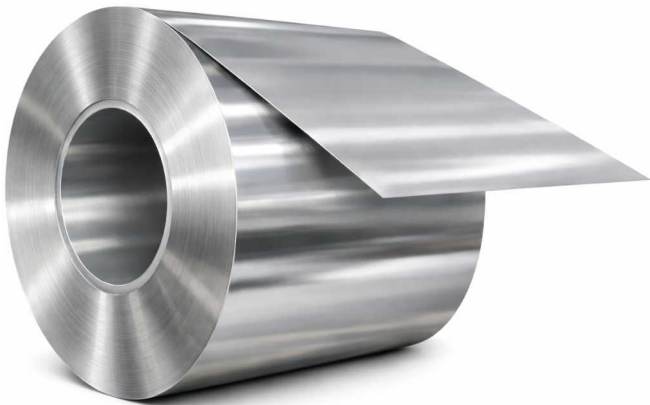

Standardized Product

Since commercially produced in the year of 1997, the **FUMIRAGRIP®** product has been receiving Indonesian National Standard (SNI) certificate and gained the Product Number Register (NRP) since officially applicable as the mandatory SNI 2053 in the year of 2024. Other than SNI, standard that used as the conversion reference is Japanese Industrial Standard (JIS) G3302 for the galvanized products, SNI 3567 and JIS G3141 for the based metal.

Selayang Pandang

FUMIRA® adalah salah satu produsen baja lembaran galvanis terbesar di Indonesia. FUMIRA® menjadi produsen pertama yang menggunakan Continuous Galvanizing Line (CGL) dengan sistem Tungku Non-Oxydizing (NOF) sejak beroperasinya pabrik FUMIRA® yang kedua di Jakarta pada tahun 1997. Teknologi ini berasal dari Nippon Steel Corp. Jepang. Sistem ini menghasilkan produk dengan kualitas lapisan Seng terbaik (kualitas lock-forming), yang disebut **FUMIRAGRIP®**, yang memiliki mampu tekuk hingga 0 (nol) celah ketebalan tanpa retak atau terkelupas berdasarkan pengujian tekuk sesuai JIS G3302. Kualitas lapisan ini sangat ideal untuk keperluan industri, khususnya otomotif dan konstruksi seperti saringan oli dan udara, badan mobil, rangka baja, partisi, atap, dinding, ducting dan floordeck.

Produk yang Terstandarisasi

Sejak diproduksi secara komersial pada tahun 1997, merek dagang **FUMIRAGRIP®** telah memperoleh sertifikat Standar Nasional Indonesia (SNI) dan mendapatkan Nomor Register Produk (NRP) sejak diberlakukannya standar wajib SNI 2053 pada tahun 2024. Selain SNI, standar yang menjadi konversi acuan adalah Japanese Industrial Standard (JIS) G3302 untuk produk galvanis, SNI 3567 dan JIS G3141 untuk logam dasarnya.

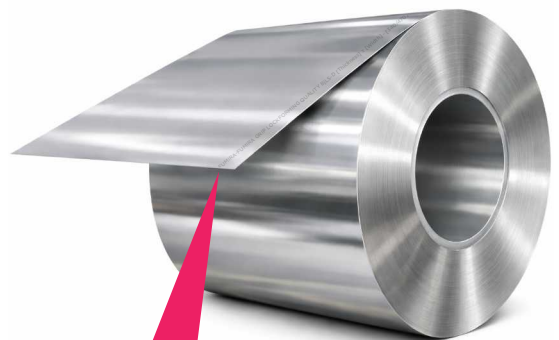

PRODUCT MARKING | PENANDAAN PRODUK

FUMIRA-FUMIRA GRIP LOCKFORMING QUALITY BjLS-D [Thickness] x [Width] - [Hardness] Z[X] SNI-2053-2024 NPB 1-104-002-26000268-5 MY

D: Cold Roll

Hardness: Soft (340) or Hard (570) M: Month Code Y: Year Code

PRODUCED WITH

NOF
Non Oxidizing
Furnace

Produced with the latest technology of Non-Oxidizing Furnace (NOF) system.

Diproduksi dengan teknologi terkini sistem *Non-Oxidizing Furnace* (NOF).

ZERO T BEND

Lockforming quality of zinc coating with bend ability up to 0 (zero) T bend without peeled off.

Pelapisan zinc kualitas lockforming dengan mampu tekuk hingga 0 (nol) celah tanpa mengelupas.

MINIMIZED SPANGLES

Metalic surface appearance with minimized spangles without deep spangles border.

Tampilan permukaan yang metalik dengan *spangles* minimum dan tanpa batas *spangles* yang di dalam.

Free of latent corrotion attack due to direct firing method usage of steel surface cleaning in the Non-Oxidizing Furnace (NOF) system galvanizing process.

Bebas dari serangan karat laten karena menggunakan metode pembakaran langsung dalam pembersihan permukaan baja di dalam sistem tungku *Non-Oxidizing* sebelum proses galvanisasi.

CORROTION FREE



Long time storage ability without color change due to oxidation.

Mampu simpan yang lama tanpa perubahan warna akibat oksidasi.

LONG TIME

STORAGE ABILITY



Non hazardous zinc coating quality standard (less than 0.003% Pb) which is comply to Green Label Indonesia.

Menggunakan standar kualitas bahan baku zinc tidak berbahaya (kurang dari 0,003%) yang sesuai dengan Green Label Indonesia.

ENVIRONMENTAL FRIENDLY



Sacrificial Protection of Zinc

In addition to the zinc oxide passivation layer formation that protects the zinc coating and base metal, when in contact with air, zinc acts as cathodic protection when the electrolysis cell is formed in the presence of rainwater or dew on the open scratched area. Cathodic protection occurs when two metals with different reduction potential are connected. One of these metals will corroded and provides protection to the other metal. The corroded metal act as anodic that oxidized is called cathodic protection metal and it can be done by any metal that has more anodic or electronegative than the other. Zinc is more anodic at the galvanic series of metal. Zinc coating on the iron or steel will naturally perform this sacrificial property from time to time until the depletion of zinc.

Galvanic series arrangement



Zinc is abundant in quantity in earth crust and chemically almost instantly react with iron at its melting point, to become alloy on the interface, makes zinc is the most applicable either economically and technically metal coating to protect iron (steel).

Perlindungan Pengorbanan Zinc

Selain membentuk lapisan pasivasi Oksida Seng yang melindungi lapisan Seng dan logam dasarnya, ketika bersentuhan dengan udara, seng bertindak sebagai pelindung katodik ketika terbentuk sel elektrolisis dengan adanya air hujan atau embun pada daerah tergores yang terbuka. Perlindungan katodik terjadi ketika dua logam dengan potensial reduksi berbeda terhubung. Salah satu logam ini akan terkorosi dan memberikan perlindungan kepada logam lainnya. Logam yang terkorosi ini bertindak sebagai anoda yang mengalami oksidasi disebut sebagai logam yang memberi perlindungan katodik dan ini dapat dilakukan oleh setiap logam yang lebih anodik atau lebih elektronegatif dari yang lain. Seng adalah logam yang bersifat lebih anodik dalam deret galvanik. Lapisan seng pada besi atau baja secara alami akan menjalani karakteristik pengorbanan ini dari waktu ke waktu sampai seng habis.

Cathodic protection mechanism on scratched galvanized steel sheet

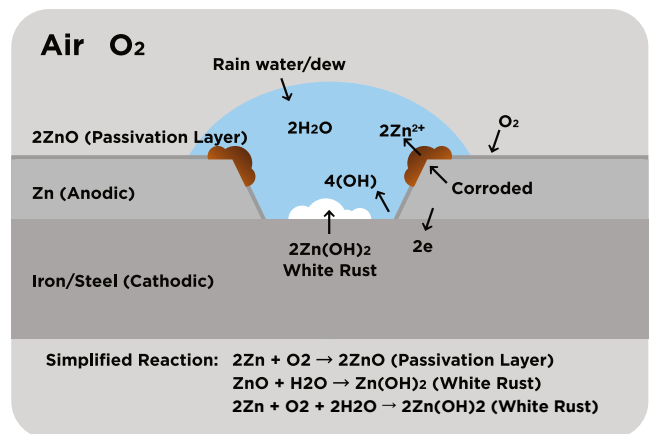

Jumlah seng yang melimpah di kerak bumi dan secara kimia hampir secara instan bereaksi dengan besi pada titik lelehnya menjadi paduan, membuat zinc menjadi logam pelapis yang paling dapat diterapkan, baik secara ekonomis maupun secara teknis untuk melindungi besi (baja).

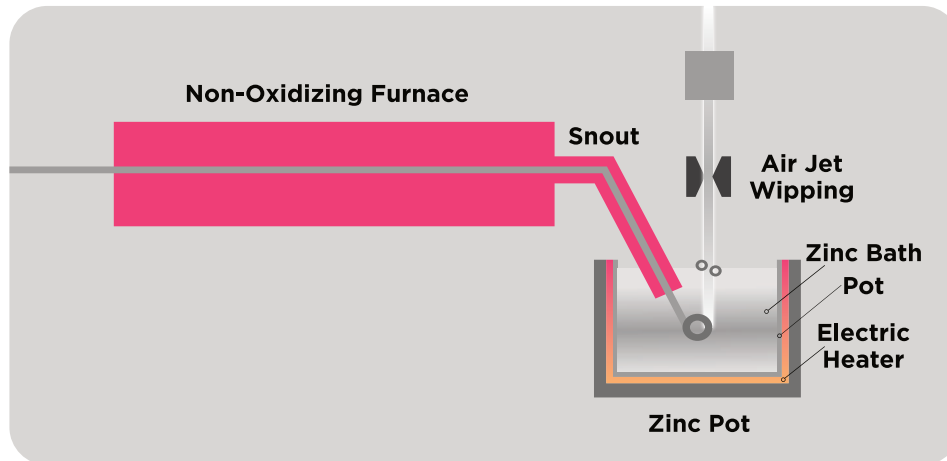

Galvanization process technology of Non-Oxidizing Furnace (NOF) is a process where prior to galvanization process, the raw materials in the form of strips of cold rolled steel is passed through a set of furnace to become oxygen-free (<5000ppm or 0.5%) or so called non-oxidizing until the process of zinc coating. The furnace is divided into several parts, i.e., preheating, to preheat and clean the surface of raw materials, Non-Oxidizing, for annealing to obtain the required mechanical properties. Radiant Tube Furnace (RTF), to maintain temperature uniformity of annealing (soaking) and cooling, to adjust the temperature of the raw material for hot dip galvanizing process. Then the steel strip directly into the pot containing hot liquid zinc (zinc bath) that connected through a closed channels, called Snout, to prevent oxidation from air and provides a very strong zinc coating to the surface of the steel strip. When out of the Zinc Bath, the Zinc coating is controlled by the Air Jet Wiping (AJW) to ensure the coating thickness and uniformity.

Teknologi proses galvanisasi tungku Non-Oxidizing (NOF) adalah proses di mana sebelum proses galvanisasi, bahan baku berupa strip baja canai dingin dilewatkan melalui satu set tungku agar bebas oksigen (<5000ppm atau 0,5%) atau non-oxidizing hingga proses pelapisan seng. Tungku terdiri dari beberapa bagian; Preheating untuk pemanasan awal dan pembersihan permukaan bahan baku. Tungku Non-Oxidizing untuk penganilan agar mendapatkan sifat mekanik yang diinginkan. Tungku Radiant Tube (RTF) untuk menjaga keseragaman temperatur anil (soaking) dan cooling. Untuk menyesuaikan temperatur bahan baku dengan proses galvanisasi celup panas. Kemudian strip baja langsung masuk ke dalam pot yang berisi cairan panas seng (Zinc Bath) yang terhubung melalui saluran tertutup, yaitu Snout, untuk mencegah oksidasi dari udara luar dan memberikan lapisan seng yang sangat kuat ke permukaan strip baja. Ketika keluar dari Zinc Bath, lapisan seng dikendalikan oleh Air Jet Wiping (AJW) untuk memastikan ketebalan dan keseragaman pelapisan.

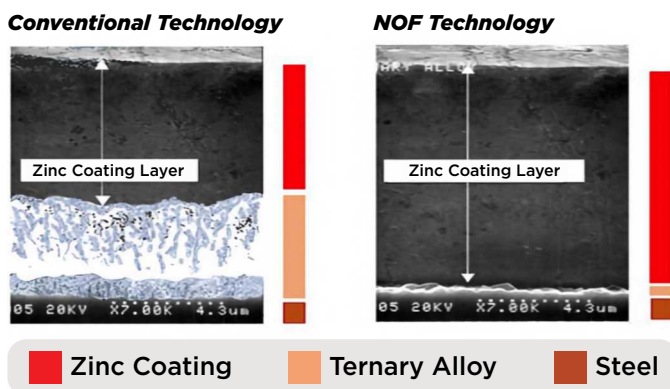

Non-Oxidizing Furnace (NOF) technology allows galvanized steel sheet product has the ability of 0 (zero) T, or lockforming quality that the product can be bended up to gap of 0 (zero) thickness (180°) without any coating crack or peeled off.

Teknologi tungku Non-Oxidizing (NOF) memungkinkan produk baja lembaran galvanis yang dihasilkan memiliki kemampuan 0 (zero) T atau kualitas lockforming, di mana produk dapat ditekuk hingga 0 (nol) celah ketebalan (180°) tanpa ada lapisan yang retak atau mengelupas.

Coil Product

The coil product is produced in Continuous Galvanizing Line. This product is suitable for mass production purposes, such as sheet cutting plate. FUMIRA® provides **FUMIRAGRIP®** in form of coil, range from 2 MT to 6 MT of weight.

Produk Coil

Produk berupa coil dihasilkan dari Continuous Galvanizing Line. Produk ini sesuai untuk kebutuhan produksi masal seperti potongan pelat. FUMIRA® menyediakan **FUMIRAGRIP®** dalam bentuk coil dengan berat dari 2 MT hingga 6 MT.

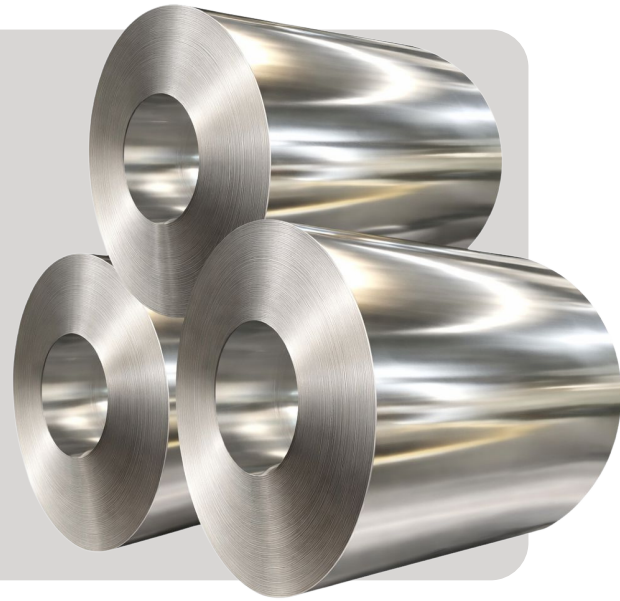

Small Coil Product

Small coil product is resulted from the recoiling in Small Coil Line. Small inside coil diameter of 140mm and 300mm and maximum weight of 300kg. Very easy to be handled for small industrial purposes.

Produk Coil Kecil

Produk coil kecil dihasilkan dari penggulungan kembali di Small Coil Line. Diameter dalam coil yang kecil antara 140mm dan 300mm dan berat maksimum 300kg yang sangat mudah untuk ditangani untuk keperluan industri kecil.

Sheet Plate

Sheet plate product produced from cutting process in the Shearing Line. With the maximum length of 4 meters, this product has tight flatness and size tolerance made it suitable for advanced processing precision with a high level, such as metal stamping and seamed drum container.

Lembaran Pelat

Produk lembaran pelat dihasilkan dari proses pemotongan di Shearing Line. Dengan panjang maksimal hingga 4 meter, produk ini memiliki kerataan dan toleransi ukuran yang ketat sehingga sesuai untuk proses lanjut dengan tingkat presisi tinggi seperti *metal stamping* dan pembuatan *drum container* dengan metode *seaming*.

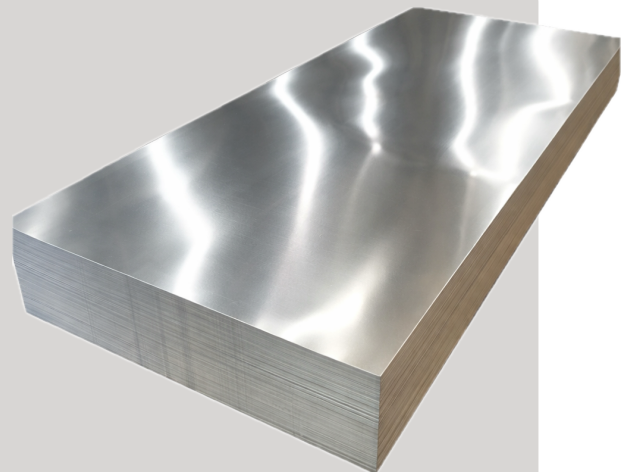

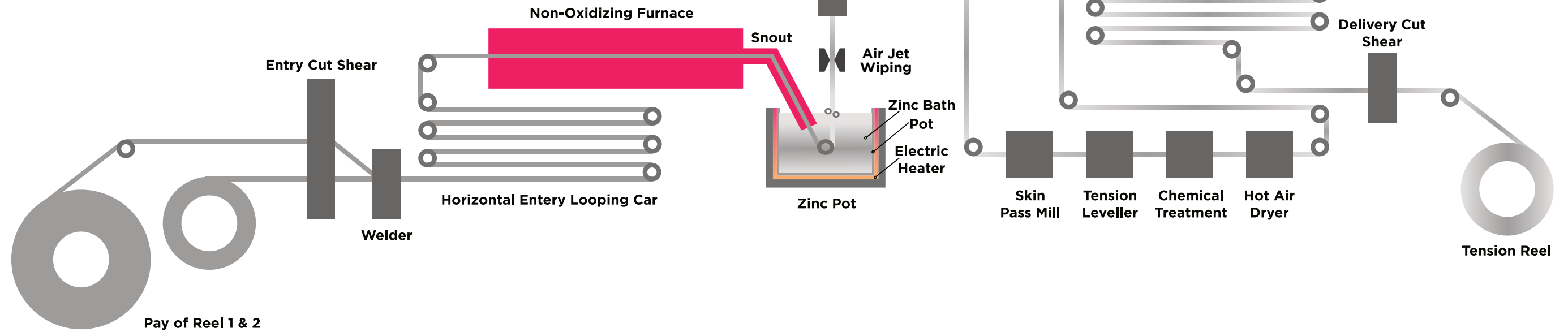

Raw Material

The raw material is full hard (unannealed) Cold Rolled Steel Sheet in Coil (CRC), as specified in JIS G314 and SNI 3567 standard. The raw material is uncoiled in the Pay Off Reel to be processed as a long strained steel strip along the Continuous Galvanizing Line.

Bahan Baku

Bahan baku produk FUMIRA® merupakan baja gulungan canai dingin *full hard* (tidak dianil) sesuai spesifikasi dalam standar JIS G3141 dan SNI 3567. Bahan baku ini dibuka di Pay Off Reel untuk diproses sebagai bentangan lembaran baja panjang sepanjang Continuous Galvanizing Line.



Annealing

The process where the raw material cold rolled strip is passed through a set of oxygen-free furnaces or non-oxidizing to pre-heat and clean its surface from oil, dirt, and oxide (corrosion) and anneal to get the required mechanical properties, full hard (unannealed) or soft (annealed) and to cool it down to the suitable temperature for hot dip galvanizing process.

Penganilan

Proses di mana bahan baku berupa lembaran baja canai dingin dilewatkan melalui satu set tungku bebas oksigen atau *non-oxidizing* untuk pemanasan awal dan pembersihan permukaannya dari minyak, kotoran, dan oksida (korosi) serta penganilan untuk mendapatkan sifat mekanik yang diperlukan, *full hard* (tidak dianil) atau lunak (dianil) dan mendinginkannya ke temperatur yang sesuai untuk proses galvanisasi celup panas.



Hot Deep Galvanizing

The process where the cleaned and annealed raw material of cold rolled steel strip from the furnaces is then hot dipped into a temperature controlled zinc bath which is linked through a sealed snout to prevent oxidation from outside air and give a very strong zinc coating to its surface. The thickness and the uniformity of zinc coating is controlled by Air Jet Wiping (AJW).

Galvanisasi Celup Panas

Proses di mana bahan baku berupa lembaran baja canai dingin yang telah dibersihkan dan dianil dari tungku kemudian dicelupkan ke dalam cairan panas zinc yang suhunya dikontrol dan terhubung melalui saluran tertutup untuk mencegah oksidasi dari udara luar dan memberikan lapisan zinc yang sangat kuat ke permukaannya. Ketebalan dan keseragaman lapisan zinc dikendalikan oleh sistem Air Jet Wiping (AJW).



Skin Passing

Skin passing is done in Skin Pass Mill (SPM) that installed in line. The facility which consist of a pair of rolls (2-High system) with specified roughness where galvanized steel sheet product is rolled by passing it through them, especially, to increase surface paint ability during the painting and color coating.

Skin Passing

Proses skin passing dilakukan di Skin Pass Mill (SPM) yang terpasang di lini produksi. Fasilitas ini terdiri dari sepasang roll (sistem 2-High) dengan kekasaran tertentu, di mana produk baja lembaran galvanis dicanai dengan melewati melaluinya, terutama, untuk memperbaiki sifat mekanik dan meningkatkan mampu cat permukaannya dalam pengecatan dan pelapisan warna.



Post Treatment

There are two process of post treatment, i.e., the process of tension leveling by Tension Leveller to improve the product shape and passivation process by surface chemical treatment using chromate liquid to prevent product from rust during the storage.

Perlakuan Pasca

Terdapat dua proses perlakuan pasca, yaitu proses penarikan dan perataan menggunakan Tension Leveller untuk memperbaiki bentuk produk dan proses pasifasi dengan perlakuan kimia permukaan menggunakan cairan *chromate* untuk mencegah produk dari karat selama penyimpanan.



Inspection and Recoiling

Inspection is done on the Inspection Table prior to recoiling to assure that product specification and quality produced comply to customer requirement. The product then is recoiled in the Tension Reel to be formed as coil and cut as customer weight requirement.

Inspeksi dan Penggulungan

Inspeksi dilakukan pada Meja Inspeksi sebelum penggulungan untuk memastikan bahwa spesifikasi dan kualitas produk yang dihasilkan sesuai dengan permintaan pelanggan. Kemudian produk digulung di Tension Reel menjadi bentuk gulungan dan dipotong sesuai kebutuhan berat dari pelanggan.

*In order to maintain **FUMIRAGRIP®** as the best zinc coated steel sheet product, **FUMIRAGRIP®** also makes Japanese Industrial Standard (JIS) G3302 as the reference standard equivalent to the SNI 2053. **FUMIRAGRIP®** also refer to raw material standard, i.e., JIS G3141, the standard for cold reduced steel sheet, in case of there is no value specified by the galvanized product standard or to have more stringent tolerance the galvanized product standard.*

Untuk menjaga **FUMIRAGRIP®** sebagai produk baja lembaran lapis seng yang terbaik, **FUMIRAGRIP®** juga menjadikan Japanese Industrial Standard (JIS) G3302 sebagai acuan standar yang setara terhadap SNI 2053. **FUMIRAGRIP®** juga mengacu kepada standar bahan baku yaitu JIS G3141, standar untuk lembaran baja canai dingin, apabila tidak ada nilai yang dispesifikasikan oleh standar produk galvanis atau untuk mendapatkan standar toleransi yang lebih ketat dari standar produk galvanis.

SNI to JIS Symbol Equivalency of Galvanized Steel Sheet

SNI 2053	JIS G 3302	Designation
BjLSK	SGCH	Commercial hard, lock forming
BjLSL	SGCC	Commercial soft, lock forming
BjLS 340	SGC 340	Commercial with tensile strenght 340 N/mm ² min., lock forming
BjLS 400	SGC 400	Commercial with tensile strenght 400 N/mm ² min., lock forming
BjLS 570	SGC 570	Commercial with tensile strenght 570 N/mm ² min., lock forming

Coating Weight and Equivalent Coating Thickness of Galvanized Steel Sheet

SNI 2053 / JIS G 3302	Average coating weight three spots (gr/m ²)	Average equivalent coating thickness (mm)
Z10	100	0.014
Z12	120	0.017
Z14	140	0.020
Z18	180	0.025
Z20	200	0.028
Z22	220	0.031
Z27	275	0.038

Note: Z12 - Z27 are made by order

Base Metal Thickness Standard & Tolerance

Nominal thickness (mm)	Nominal width & thickness tolerance (mm)		
	762	914	1219
0.20	± 0.010	± 0.010	± 0.010
0.25	± 0.040	± 0.040	± 0.040
0.30	± 0.040	± 0.040	± 0.040
0.35	± 0.040	± 0.040	± 0.040
0.40	± 0.050	± 0.050	± 0.050
0.45	± 0.050	± 0.050	± 0.050
0.50	± 0.050	± 0.050	± 0.050
0.55	± 0.050	± 0.050	± 0.050
0.60	± 0.050	± 0.050	± 0.050
0.65	± 0.060	± 0.060	± 0.060
0.70	± 0.060	± 0.060	± 0.060
0.75	± 0.060	± 0.060	± 0.060
0.80	± 0.060	± 0.060	± 0.060
0.85	± 0.060	± 0.060	± 0.060
0.90	± 0.070	± 0.070	± 0.080
0.95	± 0.070	± 0.070	± 0.080
1.00	± 0.070	± 0.070	± 0.080
1.05	± 0.070	± 0.070	± 0.080
1.10	± 0.070	± 0.070	± 0.080
1.20	± 0.070	± 0.070	± 0.080

Width and Length Standard of Galvanized Steel Sheet

Standard width (mm)	Standard length of sheet* (mm)
762**	1829; 2134; 2438; 3658
914	1829; 2134; 2438; 3658
1219	1829; 2134; 2438; 3658

* Tension levelled length. More than 3658 is not tension levelled and to be discussed

** 762mm standard width are made to order

Galvanized Sheet Width Tolerance

Nominal width (mm)	Tolerance (mm)
≤ 914	-0 / +4
> 914	-0 / +4

Galvanized Sheet Cut to Length Tolerance

Length (mm)	Tolerance (mm)
≤ 2000	+0 / +10
2000 < L ≤ 3658	+0 / +15

Bendability of Lockforming Quality

SNI 07-2053	JIS G 3302	Bending angle	Internal spacing of bend (number of sheet of nominal thickness inserted)*					
			Nominal thickness 0.2 - 1.20mm					
			Coating mass symbol					
			Z10	Z12	Z14	Z18	Z20	Z22
BjLSK	SGCH	180°	0 (zero) (Bended until no plate inserted called zero T. More stringent than galvanized products standard of SNI 2053 / JIS 3302 tolerance.)					
BjLSL	SGCC							
BjLS 340	SGC 340							
BjLS 400	SGC 400							
BjLS 570	SGC 570							

Surface Finish

Spangle	Skinpass	Passivation	Appearance
Minimized	No skinpassed	No passivation	Metallic bright
	No skinpassed	Chromate passivation	Metallic bright
	Skinpassed	No passivation	Metallic dull
	Skinpassed	Chromate passivation	Metallic dull

Chemical Composition

JIS G 3302	C (%)	Mn (%)	P (%)	S (%)
SGCH	0.18 max.	1.2 max.	0.08 max.	0.05 max.
SGCC	0.15 max.	0.8 max.	0.05 max.	0.05 max.

Mechanical Properties

Symbol	Hardness	
	Rockwell (HRB)	Rockwell (HR30T)
BjLS L	≤ 65	≤ 60
BjLS K	≥ 85	≥ 74
BjLS L2	74 to 89	66 to 76
BjLS L4	65 to 80	60 to 70
BjLS L8	50 to 71	50 to 64

Symbol	Nominal thickness (mm)					
	t ≥ 0.20		0.25 ≤ t < 0.40	0.40 ≤ t < 0.60	0.60 ≤ t < 1.0	1.0 ≤ t < 01.60
	Yield strength minimum (N/mm ²)	Tensile strength minimum (N/mm ²)	Elongation (%)			
BjLS L	-	-	-	-	-	-
BjLS K	-	-	-	-	-	-
BjLS L2	-	-	-	-	-	-
BjLS L4	-	-	-	-	-	-
BjLS L8	-	-	-	-	-	-
BjLS 340	245	340	20	20	20	20
BjLS 400	295	400	16	18	18	18
BjLS 440	335	440	16	18	18	18
BjLS 490	365	490	16	18	18	18
BjLS 570	550	570	16	16	16	16

Camber Tolerance for Sheet and Coil

Width (mm)	Camber		Coil
	Sheet length (mm)		
	≤ 2000	≥ 2000	
≥ 630	2	2 in any 2000 length	2 in any 2000 length

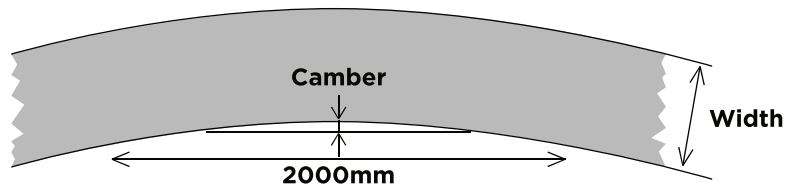

Square of Sheet Tolerance

Formula	Value (%)
$\left(\frac{D1 - D2}{2} \times \frac{1}{l}\right) \times 100\%$	≤ 0.7%

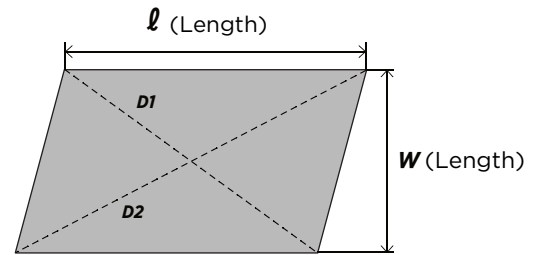

Flatness of Base Metal Tolerance for Sheet & Coil*

Width	Type		
	Bow (mm)	Edge wave (mm)	Center buckle (mm)
w ≤ 1000	2 max.	2 max.	2 max.
≥ 1000wt ≤ 1219	3 max.	2 max.	2 max.

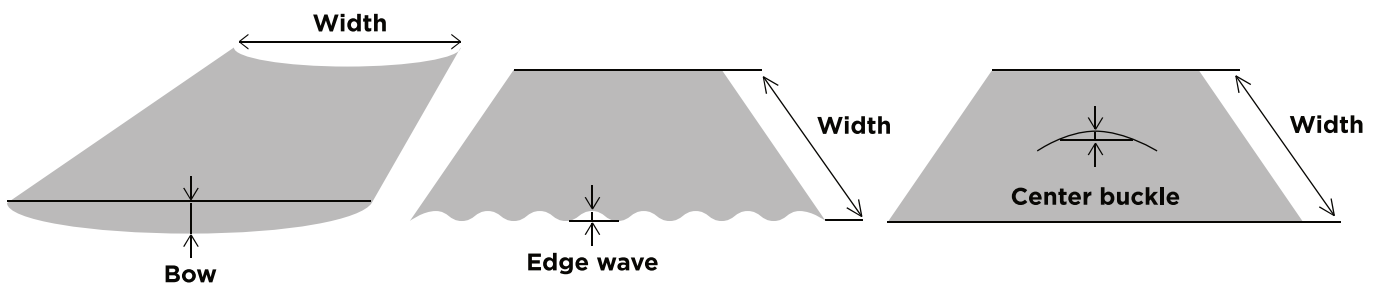

FUMIRAGRIP® end usage covers wide range of market which is divided into several segments. Some examples of the **FUMIRAGRIP®** end usage:

Penggunaan akhir **FUMIRAGRIP®** mencakup pasar yang luas yang dibagi dalam beberapa segmen. Beberapa contoh penggunaan **FUMIRAGRIP®**:

Building

- : Roofing
- Siding
- Ceiling
- Gutter
- Floordeck
- Ducting
- Fence
- Roof frame
- Cladding

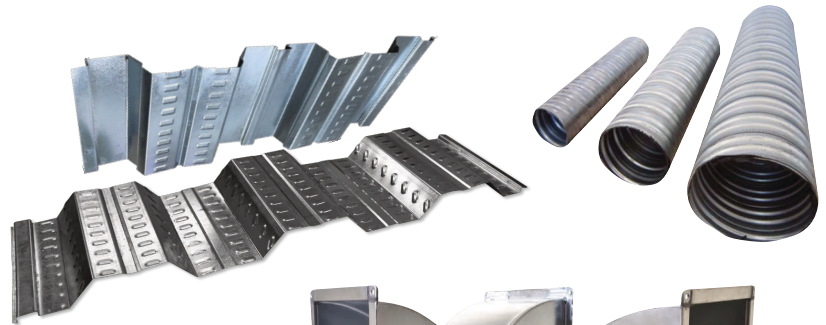

Electrical

- : Air Conditioning Case
- Cooling Showcase
- Fans
- Electrical Panel
- Refrigerators
- Freezer
- Prestressing Cable Duct
- Flexible House



Automotives

- : Bus Bodies
- Air Filter
- Oil Filter
- Sound Atenuuator

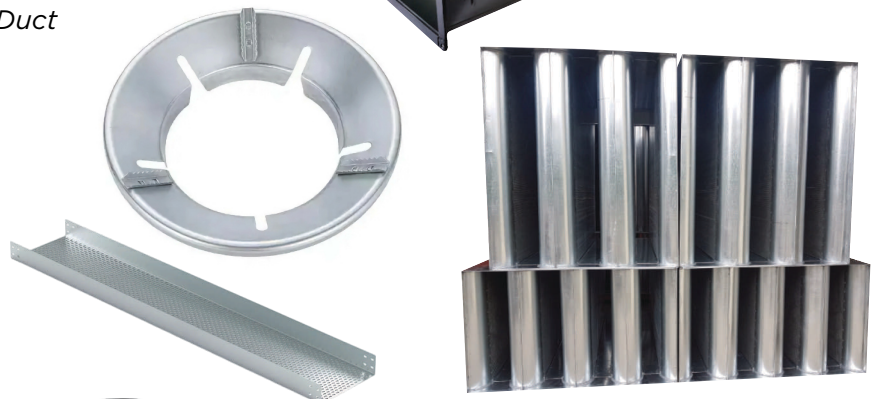

Office Equipment:

- Filling Cabinet
- Lockers
- Partition
- Rolling Door



Others

- : Billboard
- Container
- Packaging
- Etc.

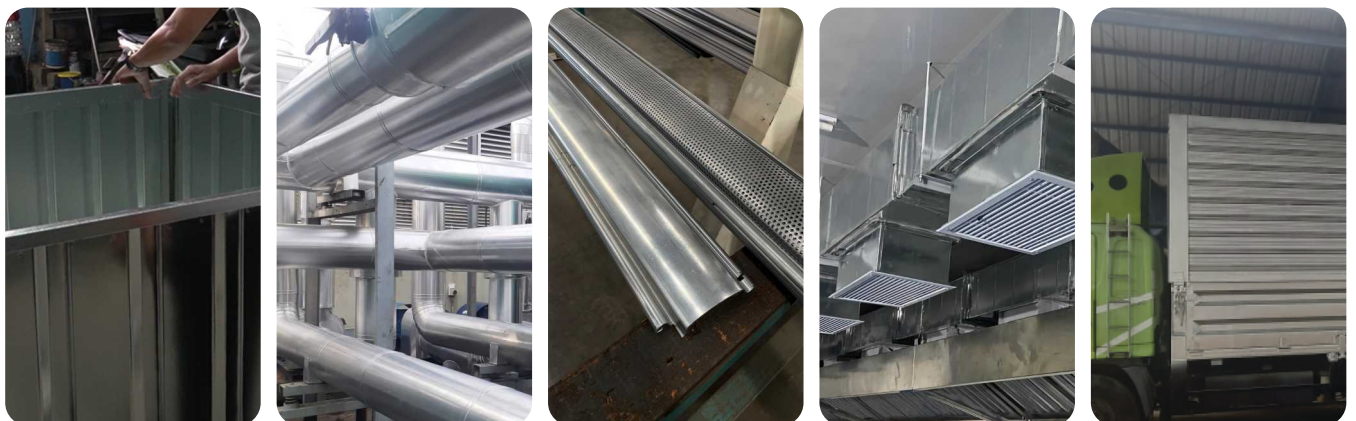

Paper Packing for Coil

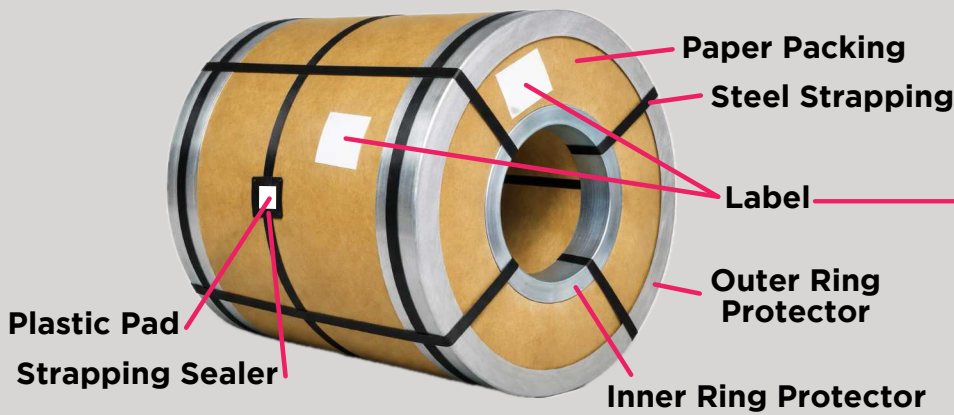

FUMIRA  	
SN: 01-2053-2006 NPB: 1-104-002-25001318-0 B: LS-D 000 L-218	
Product: FUMIRA GRIP	
COIL - Galvanized	
Batch Number:	Marking: Fumira Grip
SO Number:	
Size: (T x W):	Weight: Kg
	Act Weight: Kg
Treatment:	Hardness:
	Coating:
Unloading: 	
Sold-to: : Ship-to: : Top Color: : Back Color: :	
Petunjuk Penyimpanan: 1. Hindarkan dari hujan & simpan di tempat beratap 2. Bermanakan tutup terpal jika diperlukan 3. Simpan secara tidak bersentuhan langsung dengan lantai 4. Tidak boleh terkena air/basah/lembab	
FT/PPCJ/023-02	

Metal Packing for Coil

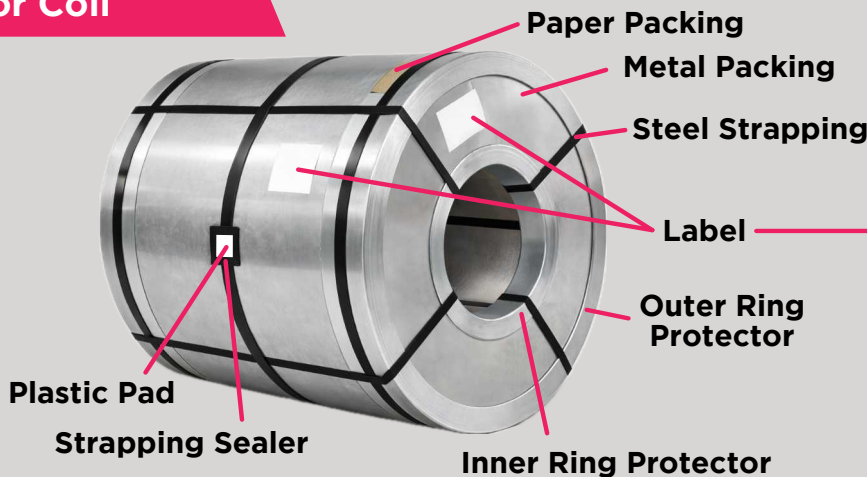

FUMIRA  	
SN: 01-2053-2006 NPB: 1-104-002-25001318-0 B: LS-D 000 L-218	
Product: FUMIRA GRIP	
COIL - Galvanized	
Batch Number:	Marking: Fumira Grip
SO Number:	
Size: (T x W):	Weight: Kg
	Act Weight: Kg
Treatment:	Hardness:
	Coating:
Unloading: 	
Sold-to: : Ship-to: : Top Color: : Back Color: :	
Petunjuk Penyimpanan: 1. Hindarkan dari hujan & simpan di tempat beratap 2. Bermanakan tutup terpal jika diperlukan 3. Simpan secara tidak bersentuhan langsung dengan lantai 4. Tidak boleh terkena air/basah/lembab	
FT/PPCJ/023-02	

Small Coil Packing



FUMIRA  	
SN: 01-2053-2006 NPB: 1-104-002-25001313-0 B: LS-D 000 L-212	
Product: FUMIRA GRIP	
ROLL - Galvanized	
Batch Number:	Marking: Moon Elephant
SO Number:	
Size: (T x W):	Weight: Kg
Length: mm	Quantity:
Treatment:	Hardness:
	Coating:
Unloading: 	
Sold-to: : Ship-to: : Top Color: : Back Color: :	
Petunjuk Penyimpanan: 1. Hindarkan dari hujan & simpan di tempat beratap 2. Bermanakan tutup terpal jika diperlukan 3. Simpan secara tidak bersentuhan langsung dengan lantai 4. Tidak boleh terkena air/basah/lembab	
FT/PPCJ/017-02	

Plastic Wrap Packing for Plate

FUMIRA			
Product: FGGIPL 0.40S1219Ch N		FUMIRA GRIP	
PLAT - Galvanized			
Batch Number: FMP1900115	Class: First Class		
SO Number: 150200328	Marking: Fumira Grip		
Size: (T x W): 0.40 x 1219	Weight: 246.73 Kg		
Length / Pc: 2438 mm	Quantity: 25 PC		
Treatment: Chromated	Hardness: Soft (G300)		
	Coating: Z18		
Unloading Pt.: SH51900491			
Top Color:			
Sold-to:			
Ship-to:			
Top Color:			
Back Color:			
Petunjuk Penyimpanan : 1. Hindarkan dari hujan & simpan di tempat beratap 2. Tambahkan tutup terpal jika diperlukan 3. Simpan secara tidak bersentuhan langsung dengan lantai 4. Tidak boleh terkena air/basah/lembab.			

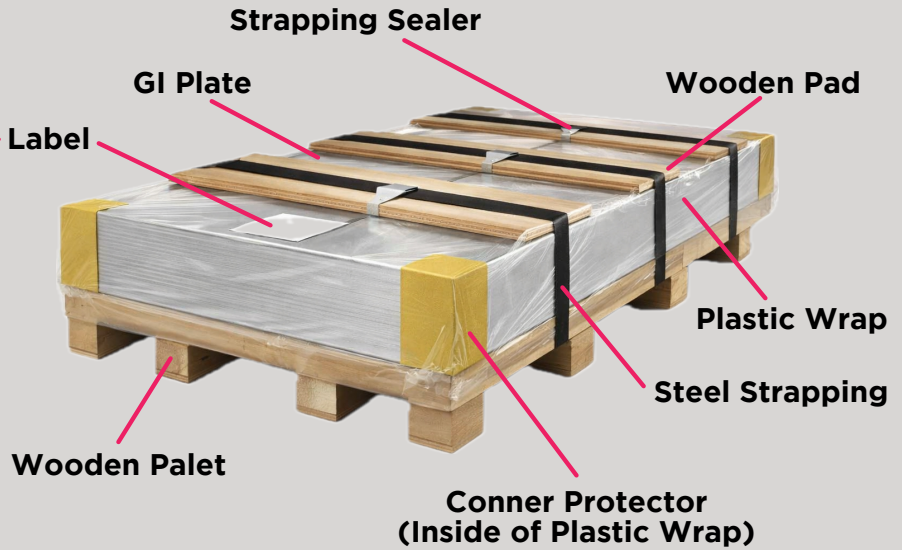

Metal Packing for Plate

FUMIRA			
Product: FGGIPL 0.40S1219Ch N		FUMIRA GRIP	
PLAT - Galvanized			
Batch Number: FMP1900115	Class: First Class		
SO Number: 150200328	Marking: Fumira Grip		
Size: (T x W): 0.40 x 1219	Weight: 246.73 Kg		
Length / Pc: 2438 mm	Quantity: 25 PC		
Treatment: Chromated	Hardness: Soft (G300)		
	Coating: Z18		
Unloading Pt.: SH51900491			
Top Color:			
Sold-to:			
Ship-to:			
Top Color:			
Back Color:			
Petunjuk Penyimpanan : 1. Hindarkan dari hujan & simpan di tempat beratap 2. Tambahkan tutup terpal jika diperlukan 3. Simpan secara tidak bersentuhan langsung dengan lantai 4. Tidak boleh terkena air/basah/lembab.			

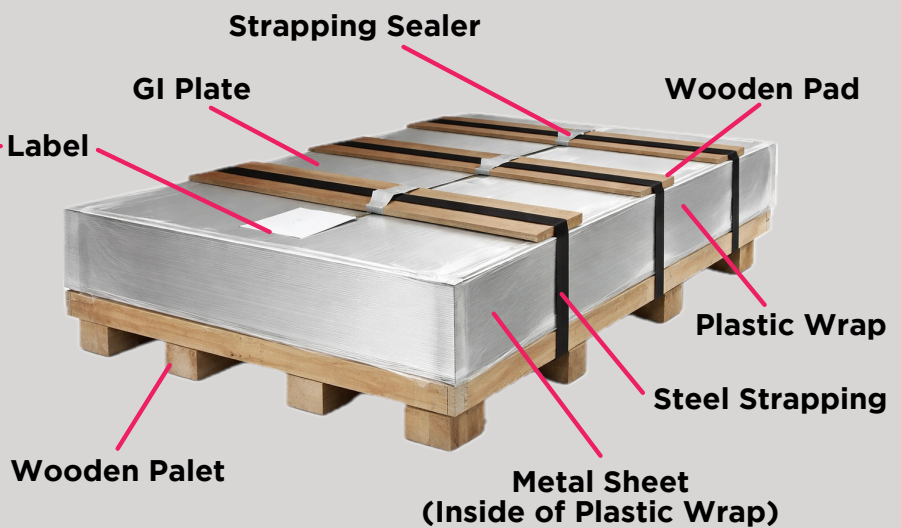



FUMIRA GRIP[®]

THE BEST
ZINC COATED STEEL SHEET
FOR DUCTING APPLICATION

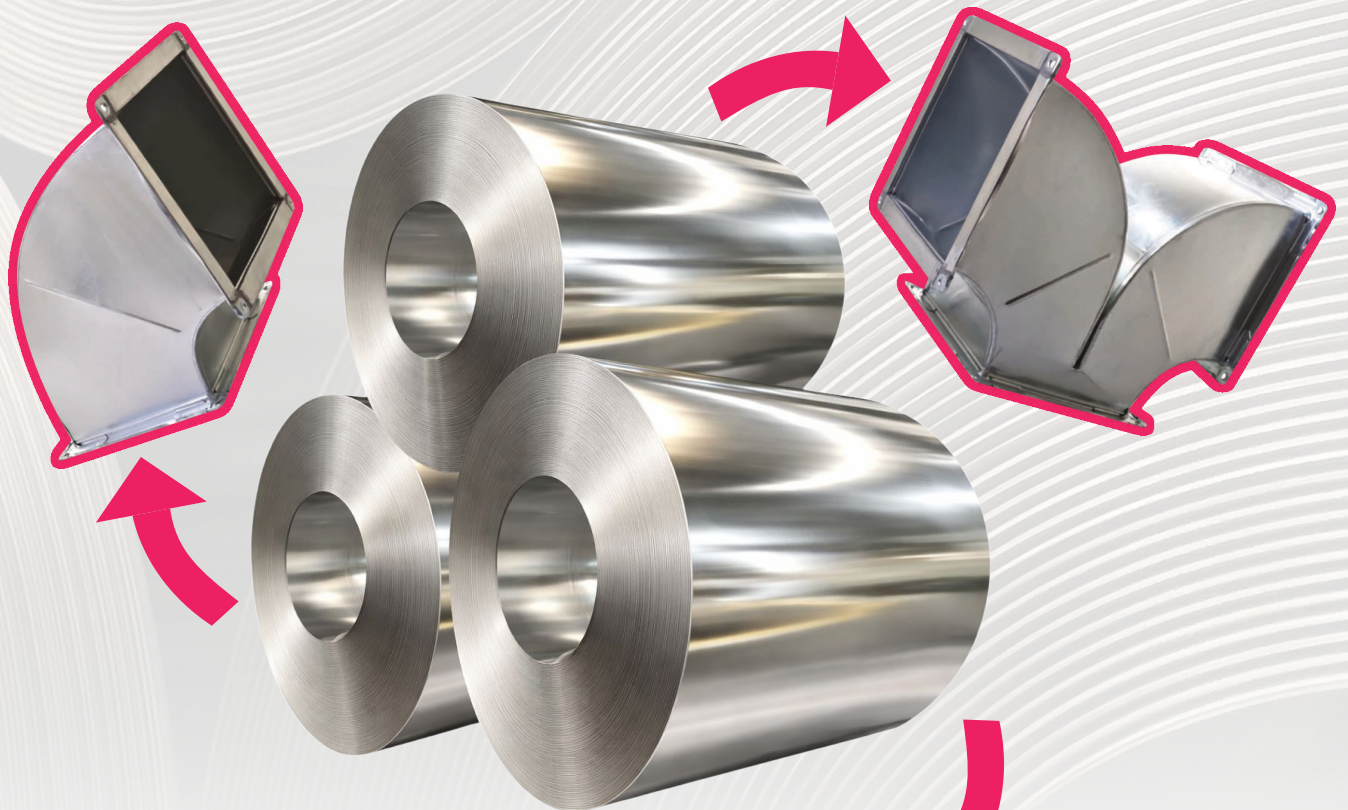

®

FUMIRA GRIP

WA Business: 0811-8803-1713

YouTube.com/FumiraOfficial

@fumira.id

www.fumira.co.id



Jakarta Factory

Kav. A-1 Bekasi Fajar Industrial Estate,
MM2100 Industrial Town, Cibitung,
Bekasi, 17520, West Java-Indonesia
(021) 898-0320 (Hunting)

Semarang Factory

Jl. Dr. Setiabudi 104 Sronol Timur,
Banyumanik, Semarang 50263,
Central Java-Indonesia
(024) 747-4447 (Hunting)

FGC3R6

